

### Centrifugal fan model TQ Es.4

Single inlet fan, direct driven with an IEC-standard motor in form B3 which is mounted on a motorbase. The overhang impeller is mounted on the motor shaft and has backwardly curved blades. The robust industrial fan is totally made of steel and painted in the agate grey color RAL 7038. The fan is suitable for the extraction of very dusty air with different types of floating materials.

#### General data:

Drive	direct	
Motor position	horizontal	
Material casing/base	Steel	
Material impeller/hub	Steel	
Coating/protection	RAL 7038	
Operating temperature (max.)	15 (80)	°C
Medium density (altitude 0 m)	1,226	kg/m <sup>3</sup>
Impeller speed	1.450	rpm
Weight	162	kg
Sound pressure level ±3 (at 1,5 m near the fan with inlet and outlet ducted, in free field)	73	dB(A)

#### Electric motor:

	112M	IEC
Power	4,0	kW
Motor speed	1.450	rpm
Electric supply	3x400V50Hz	V/Hz
Full load current	8,23	A
Enclosure	55	IP
Shape	B3T	
Efficiency class	IE3	

Grafiek TQ 631A @ 2900rpm @ 15°C @ 0m

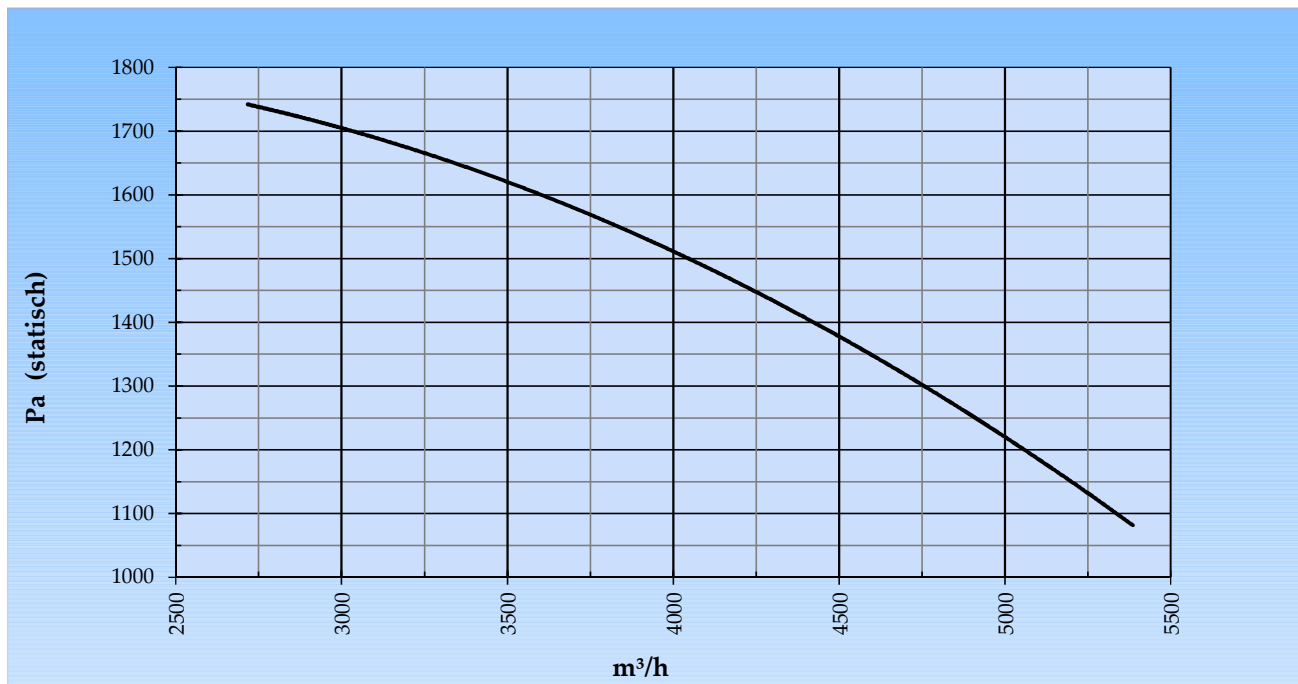

Possible discharge positions:

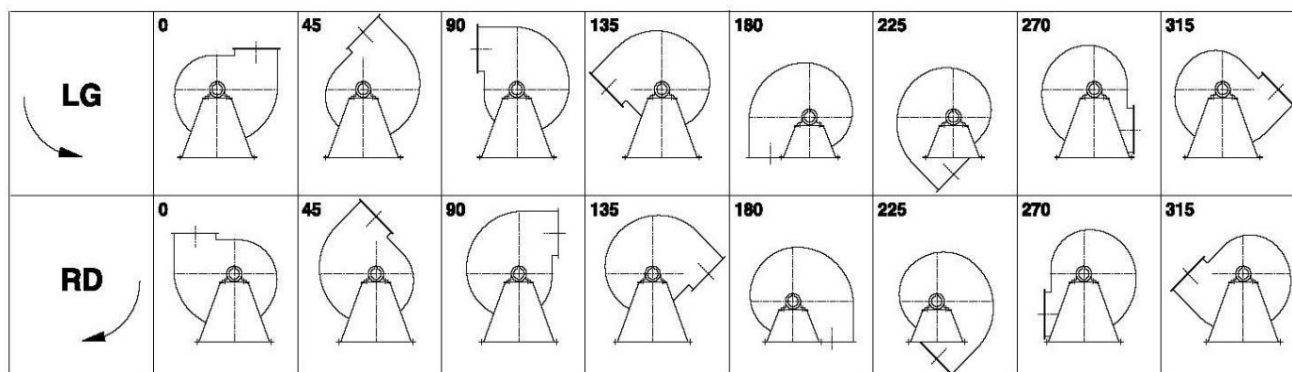

\* (Pos 180 and 225 extra price)

Possible accessories

Mounting profiles for load distribution	STF057501
Counterflange inlet/outlet	
Flexible connection inlet/outlet max. 80°C	zzØ 355 / pzØ 400
Anti-vibration mountings	4x 40x30/B/40° ShA
Inspectiondoor	
Drain	
Shaft seal without asbestos	
Coolingwheel (medium max. 150°C)	( incl. coating RAL9006 )
Flexible connection inlet/outlet max. 150°C	zzØ 355 / pzØ 400
ATEX version	Zone 1 / 2 / 21 / 22
ATEX motor	Ex nA / Exe / Ex de
Coating suitable for outdoor application	RAL 5010 / RAL ....
Stainless steel version	304 / 316 / ...
Acoustic enclosure	

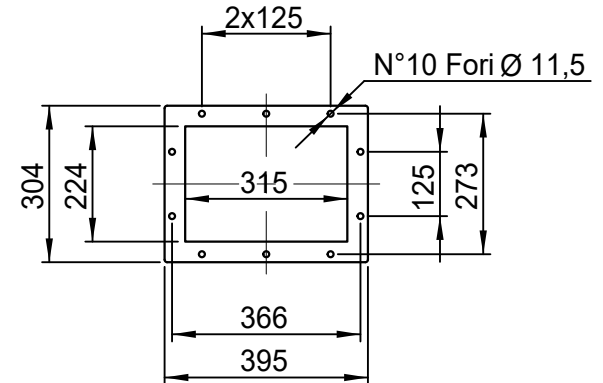
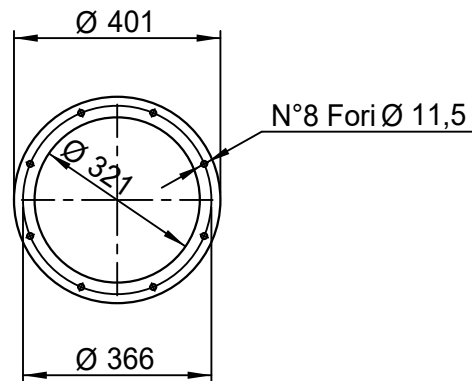
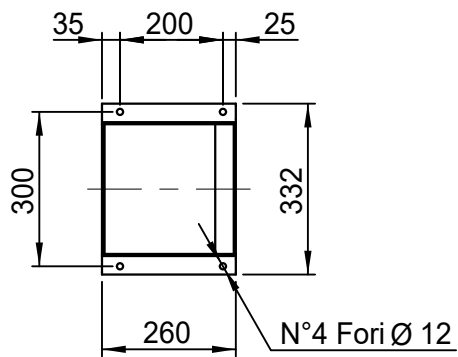
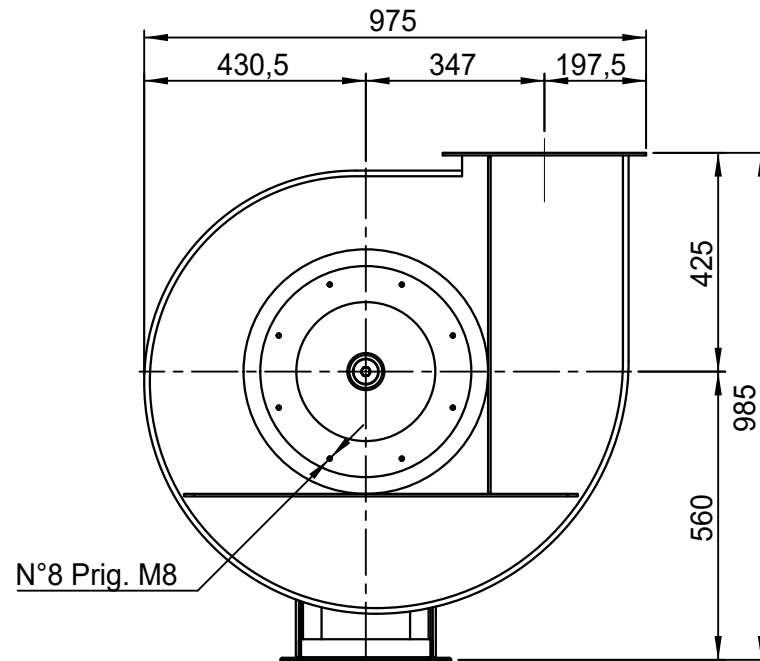
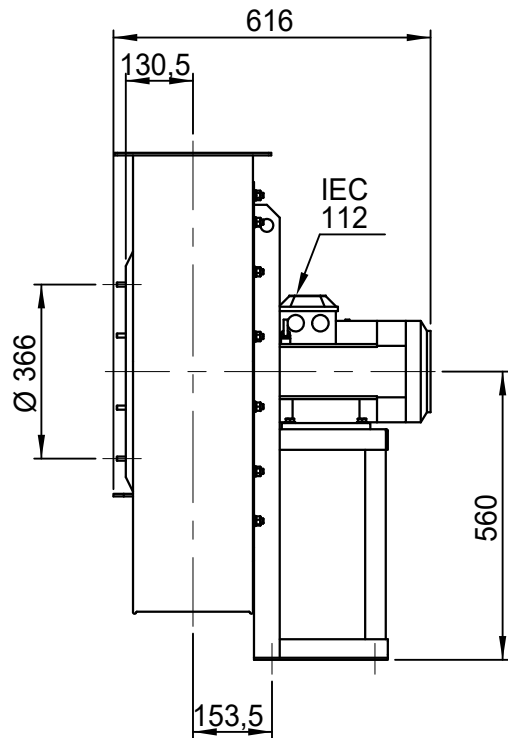

DESCRIZIONE - DESCRIPTION	SCALA	1:14	DISEGNATO - PREPARED	FORMATO
	DATA	18/09/2015	Duregotti P.	A4
	SOSTITUISCE IL - REPLACES THE N° A1TQ631A411A000			
TQ 631/A - RD 0		SOSTITUITO DAL - REPLACES BY N°		
Copy 14-9-2020	N.DISEGNO - N.DRAWING		REV.	
		V11TQ631A0007		00

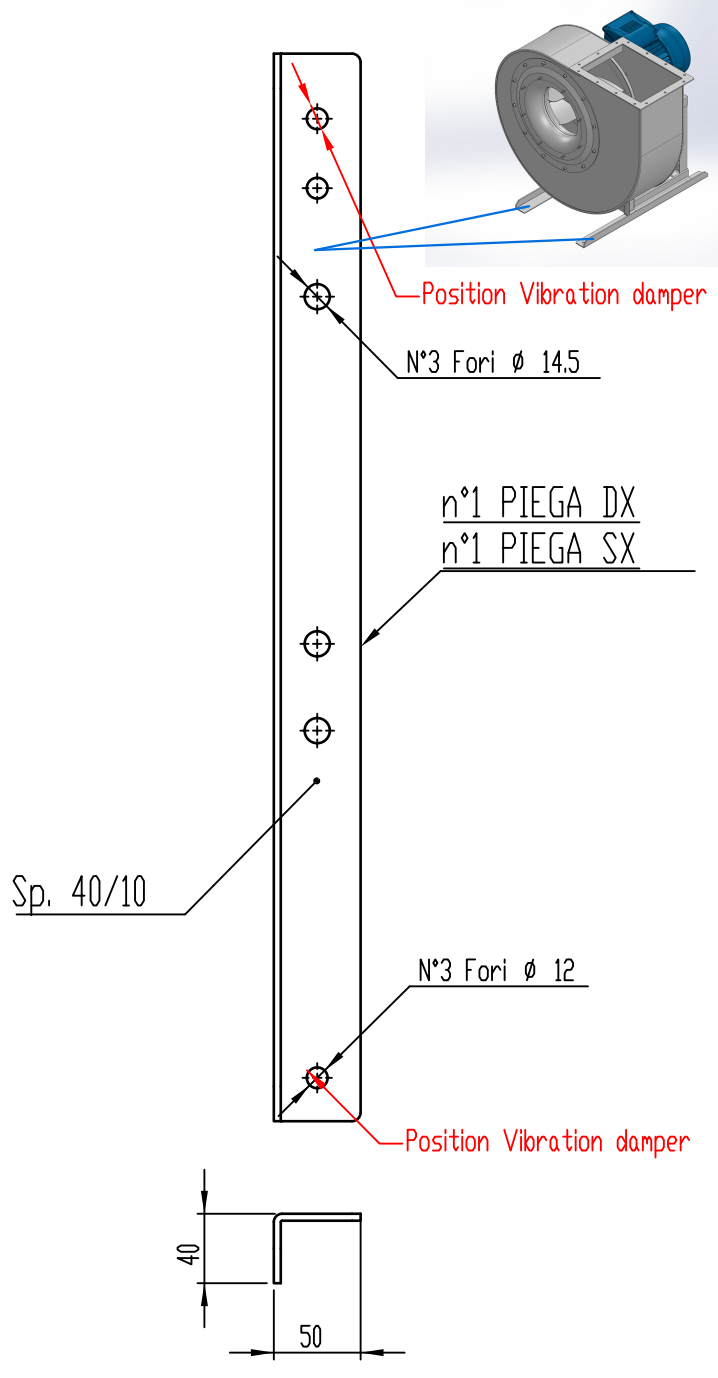
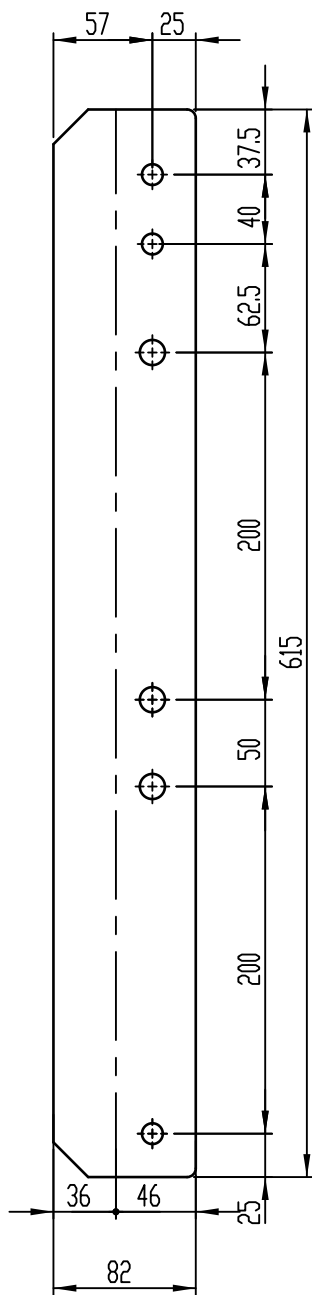

COMM.

N°

01	04/12/2019	Adattamento alle sedie nuove	Galiotto M.	De Santi G.
00	23/11/2015	PRIMA EMISSIONE	Galiotto M.	De Santi G.
REV	DATA - DATE	DESCRIZIONE - DESCRIPTION	DISEGNATO PREPARED	CONTROLLATO CHECKED
DESCRIZIONE - DESCRIPTION		MATERIALE - MATERIAL	NR.FILE	PESO - WEIGHT
Staffe per Puffer L=615 IEC 100-112-132		Fe 360	EUR00067997	Kg 1.53
		SCALA 1:4	DISEGNATO - PREPARED	FORMATO
		DATA 04/12/2019	Galiotto M.	A4
		SOSTITUISCE IL - REPLACES THE N° SOSTITUITO DAL - REPLACES BY N°		
N.DISEGNO - N.DRAWING			REV.	
STF057501			01	

