

Centrifugal fan model TH Es.4

Single inlet fan, direct driven with an IEC-standard motor in form B3 which is mounted on a motorbase. The overhang impeller is mounted on the motor shaft and has an open blade impeller. The robust industrial fan is totally made of steel and painted in the agate grey color RAL 7038. The fan is suitable for the transport of granules and trimmings in nylon; for loading solid fuels into boilers, etc.

General data:

Drive	direct	
Motor position	horizontal	
Material casing/base	Steel	
Material impeller/hub	Steel	
Coating/protection	RAL 7038	
Operating temperature (max.)	15 (80)	°C
Medium density (altitude 0 m)	1,226	kg/m ³
Impeller speed	2.945	rpm
Weight	210	kg
Sound pressure level ±3 (at 1,5 m near the fan with inlet and outlet ducted, in free field)	86	dB(A)

Electric motor:

	160M	IEC
Power	11,0	kW
Motor speed	2.945	rpm
Electric supply	3x400V50Hz	V/Hz
Full load current	20,0	A
Enclosure	55	IP
Shape	B3T	
Efficiency class	IE3	

Curve TH 502A @ 2945rpm @ 15°C @ 0m

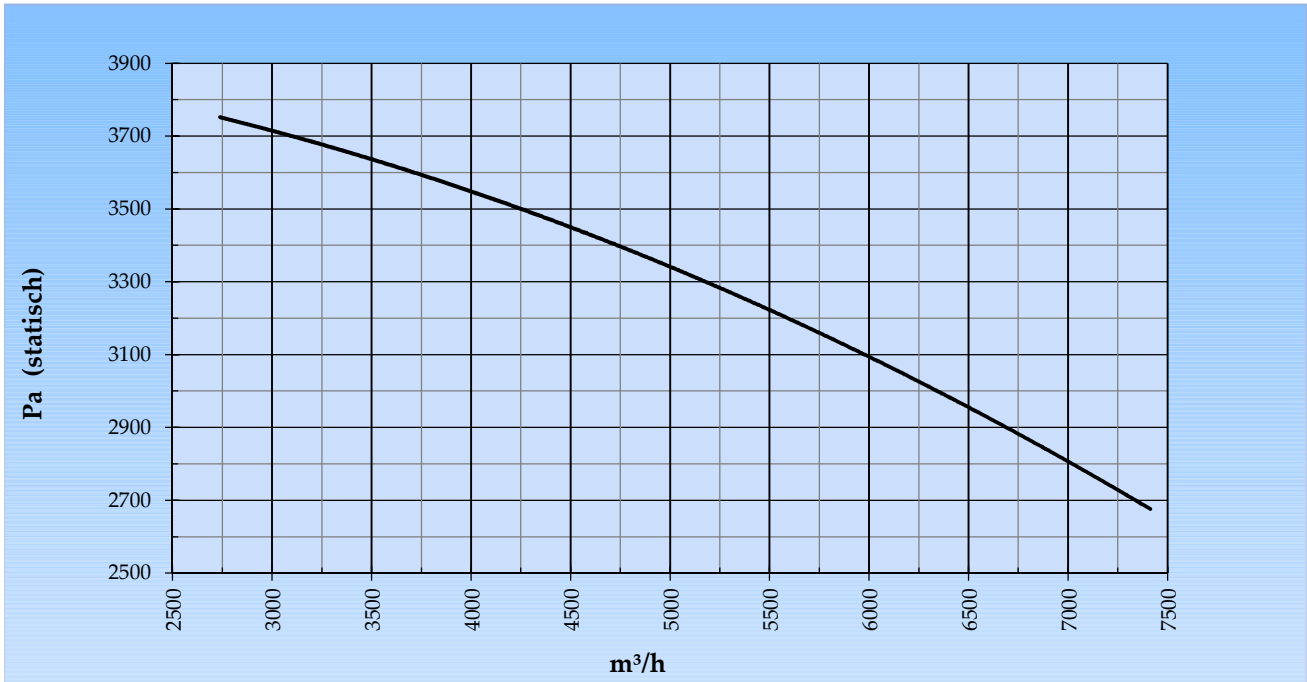

Possible discharge positions:

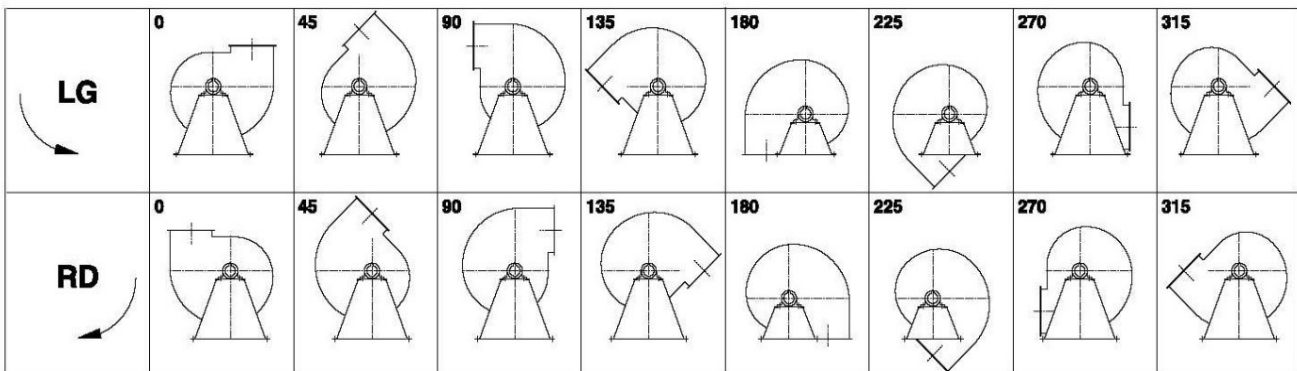

* (Pos 180 and 225 extra price)

Possible accessories

Mounting profiles for load distribution	AP16001ST
Counterflange inlet/outlet	
Flexible connection inlet/outlet max. 80°C	zzØ 321 / pz 315x224
Anti-vibration mountings	4x 40x30/B/70° ShA
Inspectiondoor	
Drain	
Shaft seal without asbestos	
Coolingwheel (medium max. 150°C)	(incl. coating RAL9006)
Flexible connection inlet/outlet max. 150°C	zzØ 321 / pz 315x224
ATEX version	Zone 1 / 2 / 21 / 22
ATEX motor	Ex nA / Exe / Ex de
Coating suitable for outdoor application	RAL 5010 / RAL
Stainless steel version	304 / 316 / ...
Acoustic enclosure	

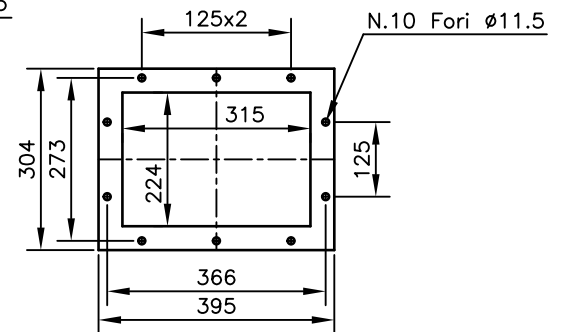
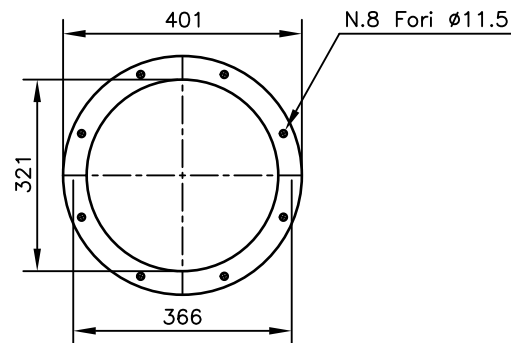
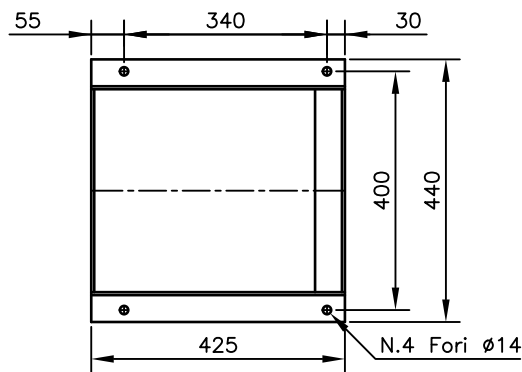
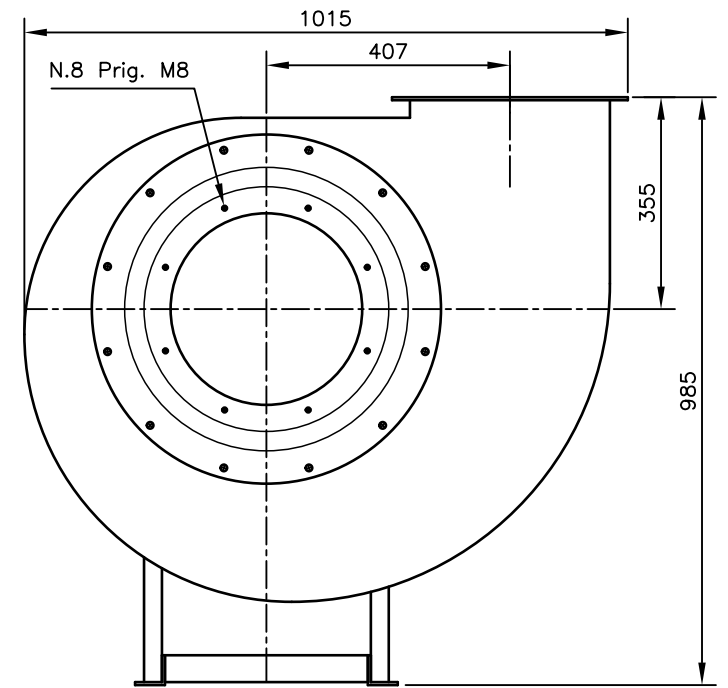
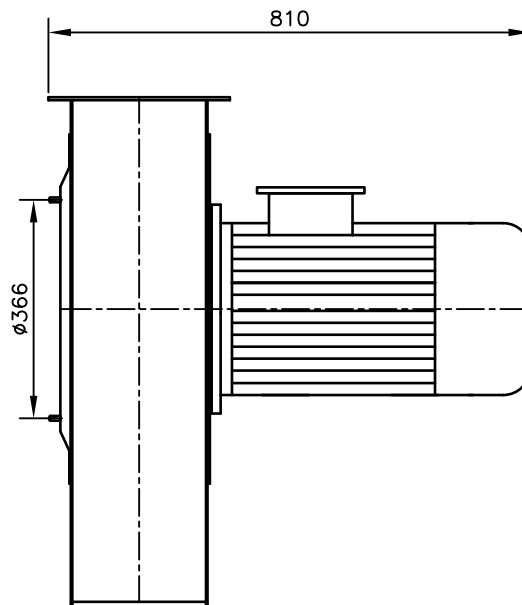
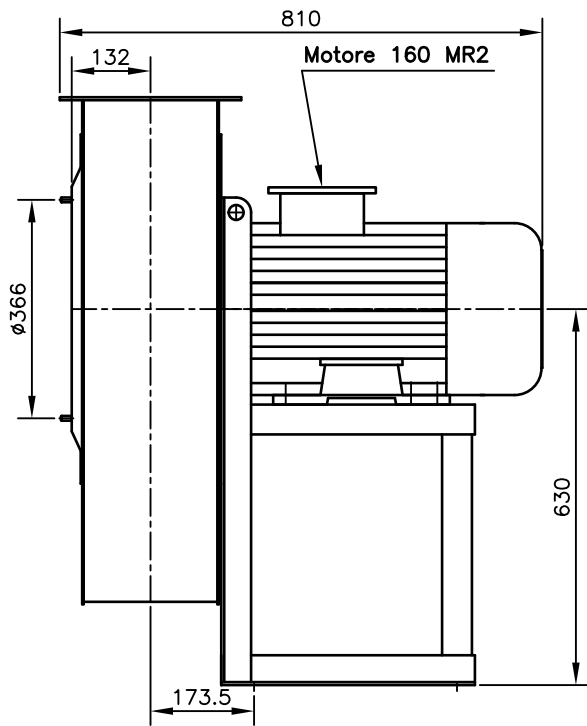

DESCRIZIONE TH 502-A RDO Mot. 160 MR2	SCALA: 1:12	PESO:	FORMATO:
	DATA:	kg .	A4
DISEGNATO:			
Copy 14-9-2020			

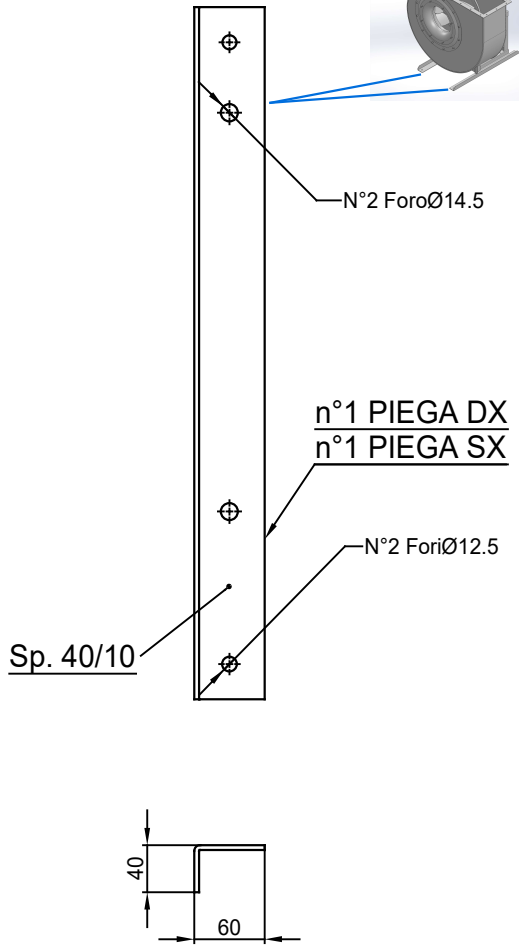
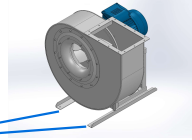
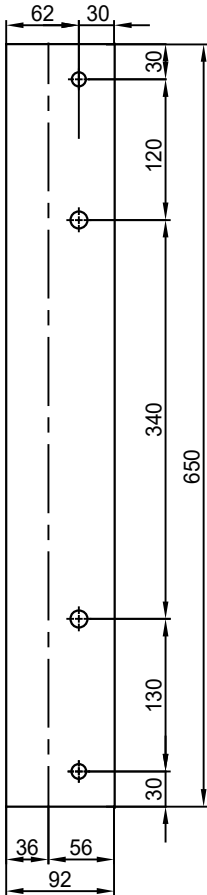

COMM.
N°

00	04/02/2016	PRIMA EMISSIONE		RK	RK
01	16/09/2020	Extension pedestal		MvS	MvS
REV	DATA - DATE	DESCRIZIONE - DESCRIPTION			APPROVATO APPROVED
DESCRIZIONE - DESCRIPTION		MATERIALE - MATERIAL	NR.FILE	PESO - WEIGHT	
DESCRIZIONE - DESCRIPTION		Fe 360		Kg	
Staffe per Puffer L=650 IEC 160 / AP series			SCALA 1:4.5	DISEGNATO - PREPARED	FORMATO
			DATA 04/02/2016	RK	A4
			SOSTITUISCE IL - REPLACED THE N°		
			SOSTITUITO DAL - REPLACES BY N°		
N.DISEGNO - N.DRAWING				REV.	
STF-AP16001ST					
				01	