

Centrifugal fan model TF, Es.4

Single inlet fan, direct driven with an IEC-standard motor in form B3 which is mounted on a motorbase. The overhang impeller is mounted on the motor shaft and has backwardly curved blades. The blades are welded between the back plate disc and the aerodynamically formed front plate. The robust industrial fan is totally made of steel and painted in the agate grey color RAL 7038. The fan is suitable for pneumatic transport, sawdust, small wood shavings and granulate.

General data:

Drive	direct	
Motor position	horizontal	
Material casing/base	Steel	
Material impeller/hub	Steel	
Coating/protection	RAL 7038	
Operating temperature (max.)	15 (80)	°C
Medium density (altitude 0 m)	1,226	kg/m ³
Impeller speed	1.450	rpm
Weight	194	kg
Sound pressure level ±3 (at 1,5 m near the fan with inlet and outlet ducted, in free field)	79	dB(A)

Electric motor:

	112M	IEC
Power	4,0	kW
Motor speed	1.450	rpm
Electric supply	3x400V50Hz	V/Hz
Full load current	57,60	A
Enclosure	55	IP
Shape	B3T	
Efficiency class	IE3	

Curve TF 801E @ 1450rpm @ 15°C @ 0m

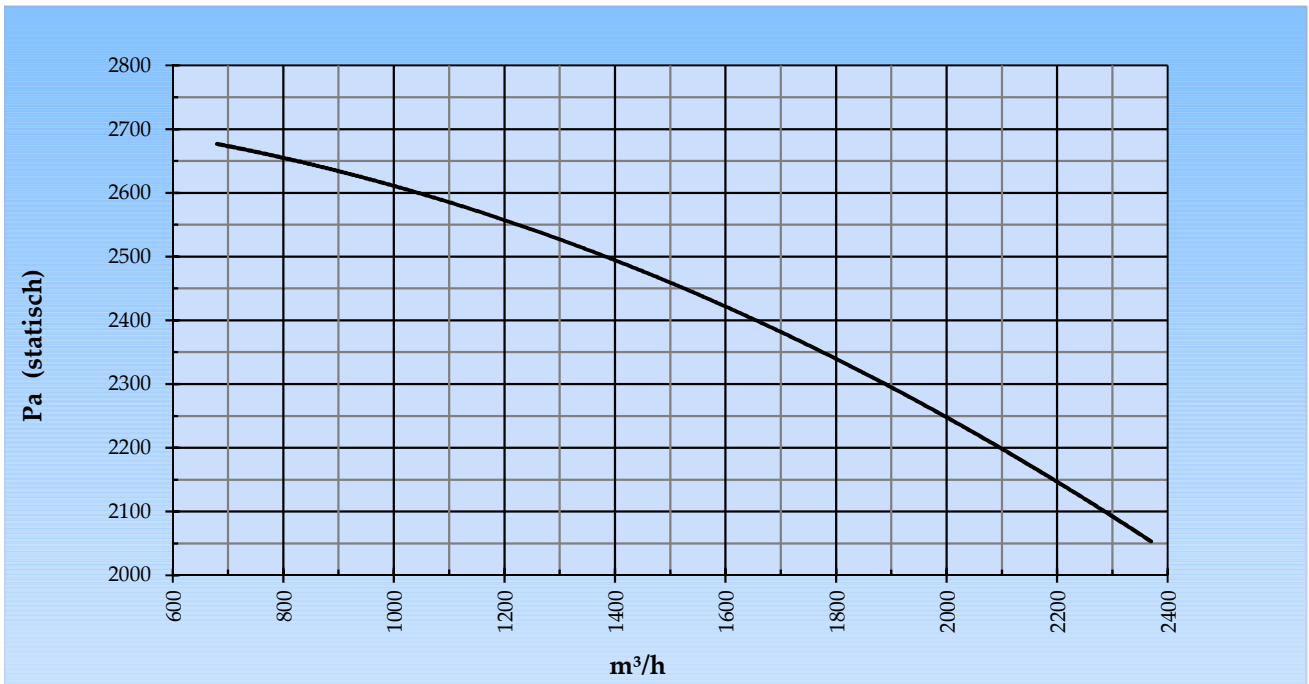

Possible discharge positions:

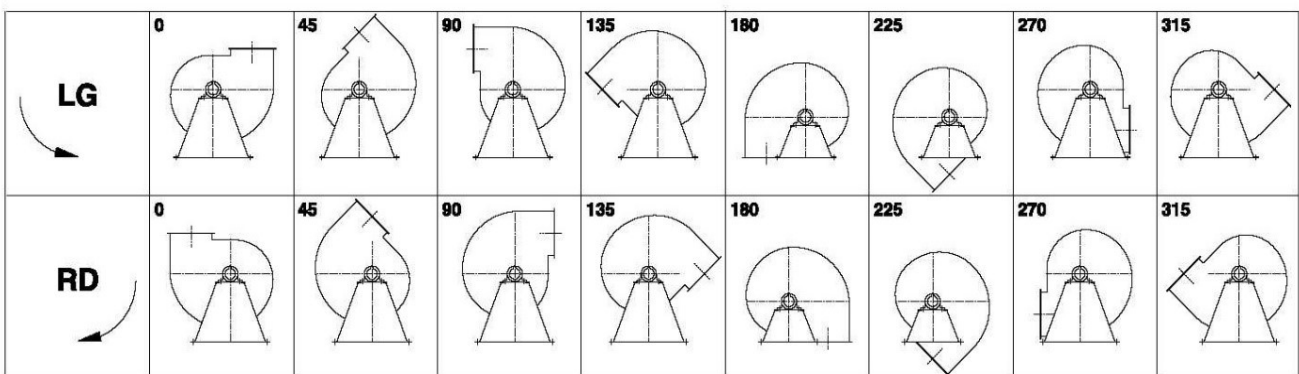

* (Pos 180 and 225 extra price)

Possible accessories

Mounting profiles for load distribution	AP100-11201ST
Counterflange inlet/outlet	
Flexible connection inlet/outlet max. 80°C	zzØ 315 / pzØ 250
Anti-vibration mountings	4x 40x30/B/40° ShA
Inspectiondoor	
Drain	
Shaft seal without asbestos	
Coolingwheel (medium max. 150°C)	(incl. coating RAL9006)
Flexible connection inlet/outlet max. 150°C	zzØ 315 / pzØ 250
ATEX version	Zone 1 / 2 / 21 / 22
ATEX motor	Ex nA / Exe / Ex de
Coating suitable for outdoor application	RAL 5010 / RAL
Stainless steel version	304 / 316 / ...
Acoustic enclosure	

ES. 4

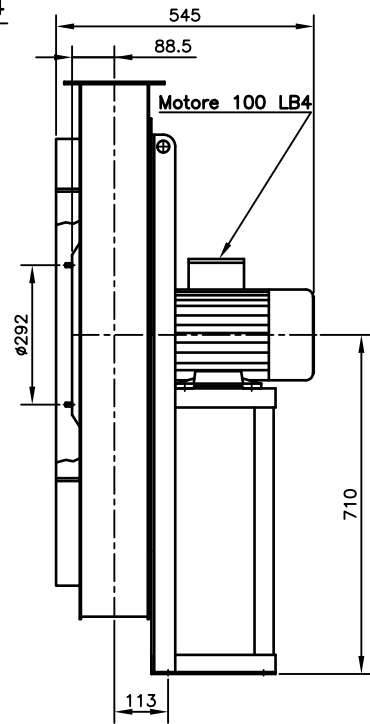

ES. 5

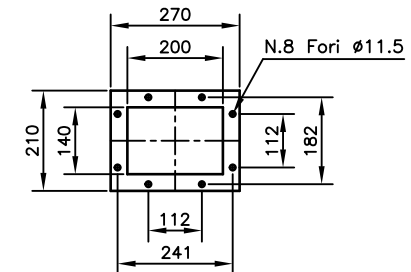
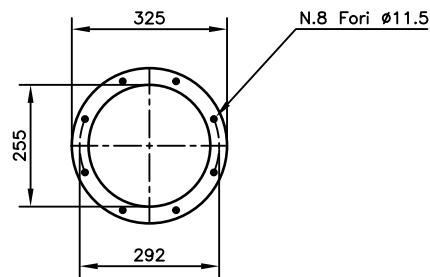
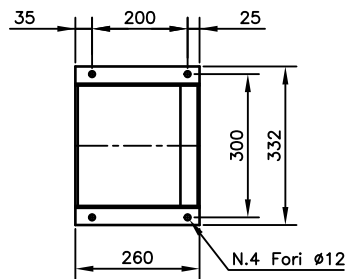
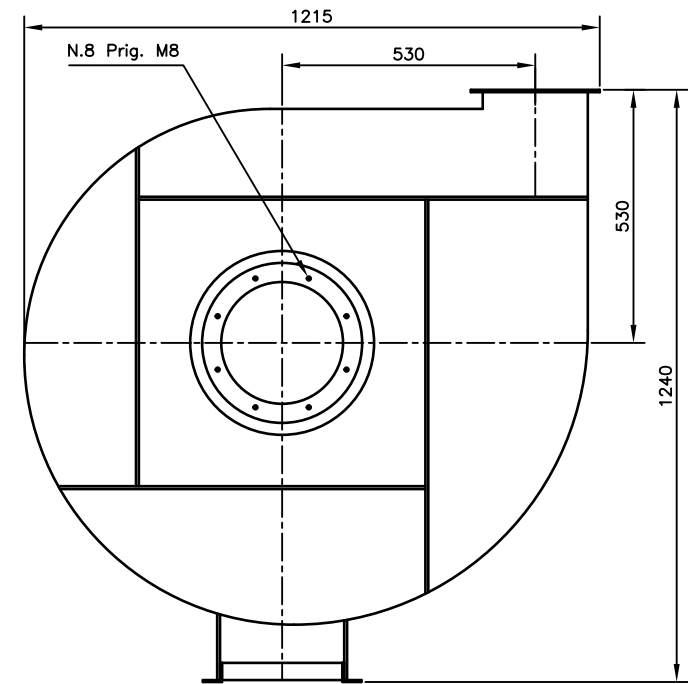
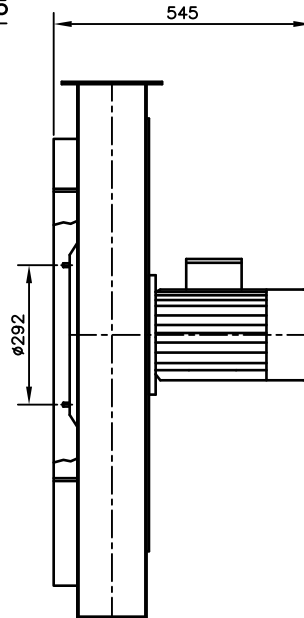

DESCRIZIONE
 TF 801-E
 RDO Es. 4-5 Mot. 112 M4

SCALA: 1:15

PESO: kg .

FORMATO: A4

DATA: .

DISEGNATO: .

Copy 25-2-2020



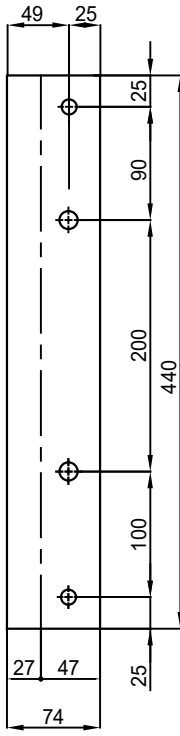

Sp. 30/10

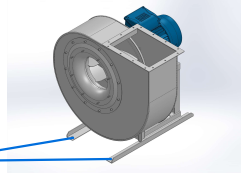

n°1 PIEGA DX
n°1 PIEGA SX

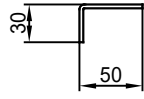

COMM.
N°

00	02/02/2016	PRIMA EMISSIONE		RK	RK
01	16/09/2020	Extention pedestal		MvS	MvS
REV	DATA - DATE	DESCRIZIONE - DESCRIPTION		DISEGNATO PREPARED	CONTROLLATO CHECKED
DESCRIZIONE - DESCRIPTION		MATERIALE - MATERIAL	NR.FILE	PESO - WEIGHT	
		Fe 360		Kg	
DESCRIZIONE - DESCRIPTION			SCALA 1:4	DISEGNATO - PREPARED	FORMATO
Staffe per Puffer L=440 IEC 100-112 / AP series			DATA 02/02/2016	RK	A4
			SOSTITUISCE IL - REPLACED THE N° SOSTITUITO DAL - REPLACES BY N°		
N.DISEGNO - N.DRAWING				REV.	
STF-AP10011201ST				01	

