



Centrifugal fan model MPR, Es.4

Single inlet fan, direct driven with an IEC-standard motor in form B3 which is mounted on a motorbase. The overhang impeller is mounted on the motor shaft and has backwardly curved blades. The blades are welded between the back plate disc and the aerodynamically formed front plate. The robust industrial fan is totally made of steel and painted in the agate grey color RAL 7038. The fan is suitable for the transportation of clean and slightly dusty air.

General data:

Drive	direct	
Motor position	horizontal	
Material casing/base	Steel	
Material impeller/hub	Steel	
Coating/protection	RAL 7038	
Operating temperature (max.)	15 (80)	°C
Medium density (altitude 0 m)	1,226	kg/m ³
Impeller speed	2.910	rpm
Weight	79	kg
Sound pressure level ±3 (at 1,5 m near the fan with inlet and outlet ducted, in free field)	75	dB(A)

Electric motor:	100L	IEC
Power	3,0	kW
Motor speed	2.910	rpm
Electric supply	3x400V50Hz	V/Hz
Full load current	5,77	A
Enclosure	55	IP
Shape	B3T	
Efficiency class	IE3	

Curve MPR 452 @ 2910rpm @ 15°C @ 0m

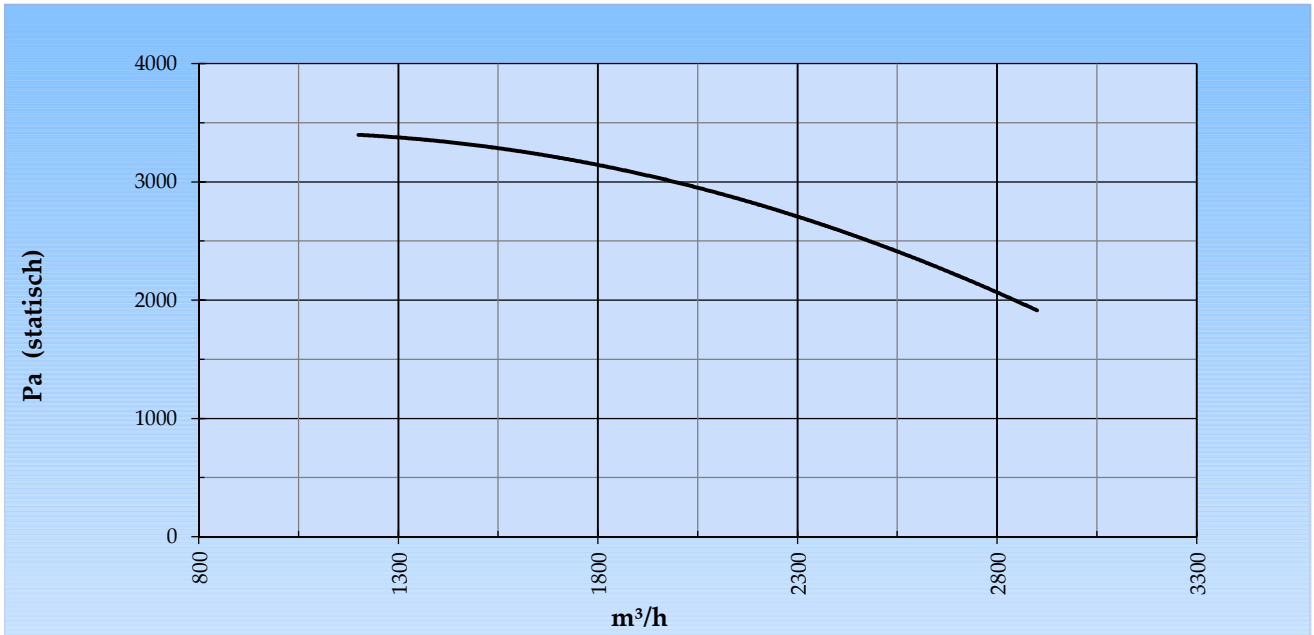

Possible discharge positions:

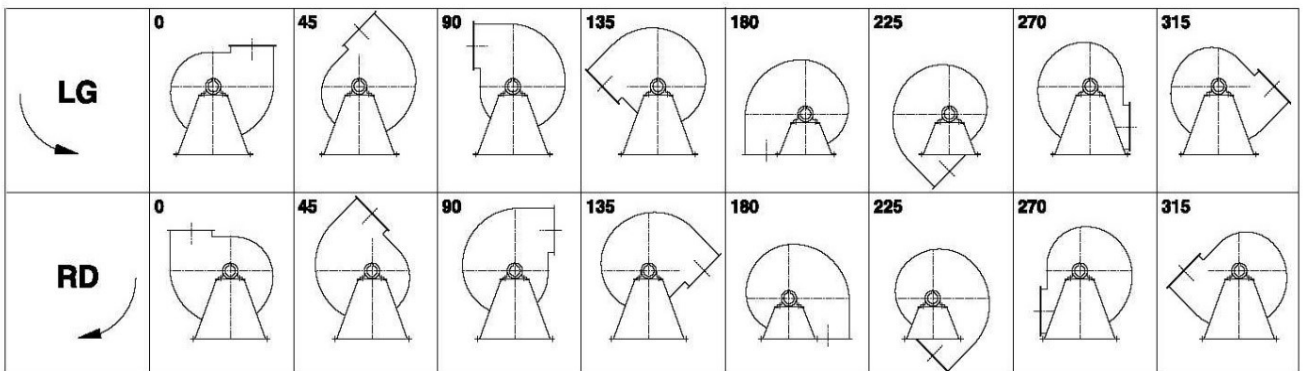

* (Pos 180 and 225 extra price)

Possible accessories

Mounting profiles for load distribution	STF 047501ST
Counterflange inlet/outlet	
Flexible connection inlet/outlet max. 80°C	zzØ 250 / pzØ 250
Anti-vibration mountings	4x 30x20/B/40° ShA
Inspectiondoor	
Drain	
Shaft seal without asbestos	
Coolingwheel (medium max. 150°C)	(incl. coating RAL9006)
Flexible connection inlet/outlet max. 150°C	zzØ 250 / pzØ 250
ATEX version	Zone 1 / 2 / 21 / 22
ATEX motor	Ex nA / Exe / Ex de
Coating suitable for outdoor application	RAL 5010 / RAL
Stainless steel version	304 / 316 / ...
Acoustic enclosure	

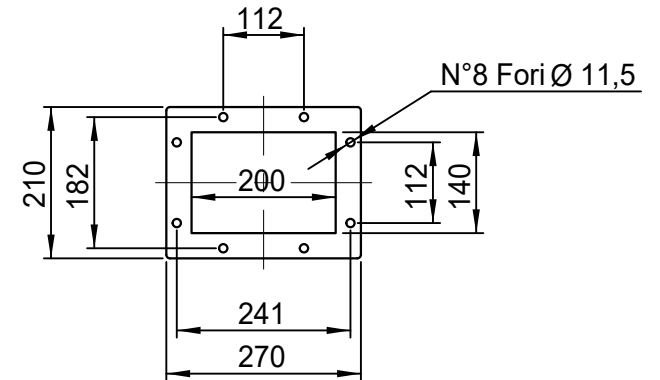
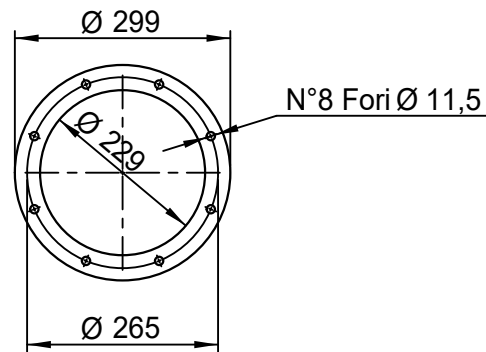
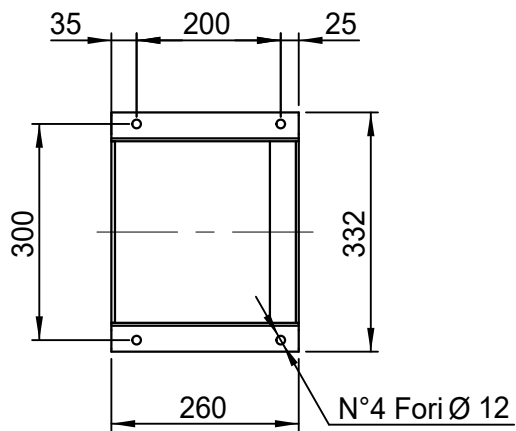
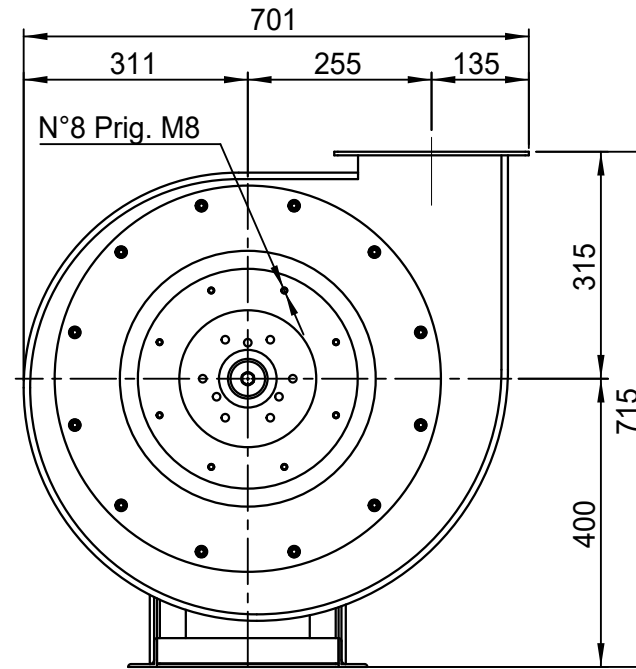
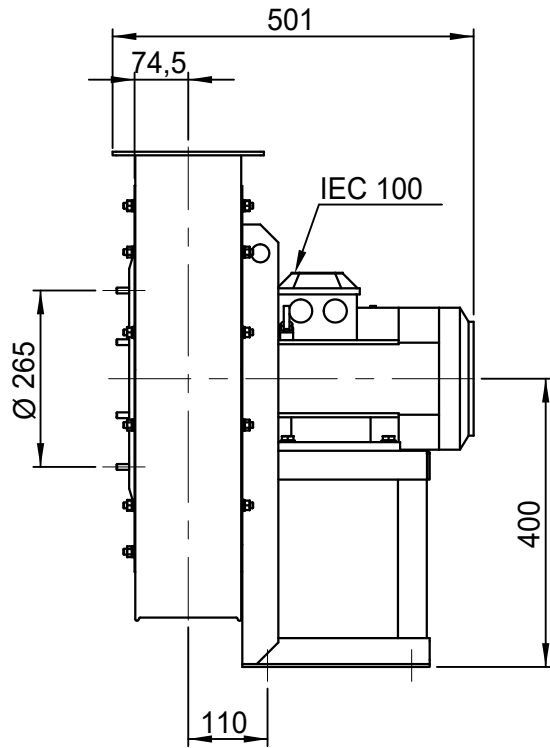

DESCRIZIONE - DESCRIPTION	SCALA	1:10	DISEGNATO - PREPARED	FORMATO
	DATA	31/07/2015	Duregotti P.	A4
MPR 452 - RD 0	SOSTITUISCE IL - REPLACES THE N° A1PR452A411A000			
	SOSTITUITO DAL - REPLACES BY N°			
Copy 13-7-2020	N.DISEGNO - N.DRAWING		REV.	
		V1MPR452A0012		00

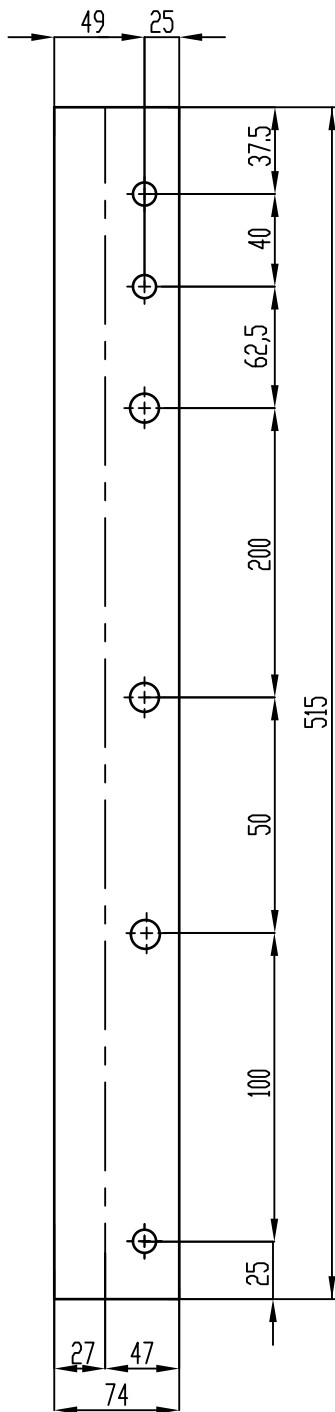

Sp. 30/10

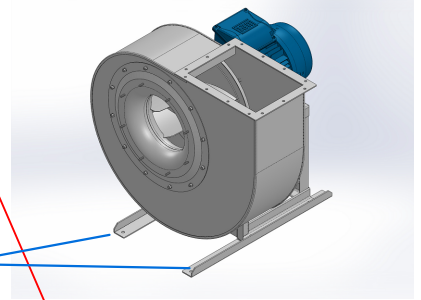

Position Vibration damper

N° 1 Foro \varnothing 14,5

n°1 PIEGA DX
n°1 PIEGA SX

N°3 Fori \varnothing 10

Position Vibration damper

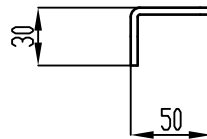

COMM.

N°

01	17/1/2020	Adattamento a sedie nuove	AL	AL
00	14/1/2016	PRIMA EMISSIONE	RK.	RK
REV	DATA - DATE	DESCRIZIONE - DESCRIPTION	DISEGNATO PREPARED	CONTROLLATO CHECKED
DESCRIZIONE - DESCRIPTION		MATERIALE - MATERIAL	NR.FILE	PESD - WEIGHT
		Fe 360	EUR00067975	Kg 0.64
DESCRIZIONE - DESCRIPTION Staffe per Puffer L=515 IEC 100-112-132			SCALA 1:3	DISEGNATO - PREPARED
			DATA 04/12/2019	Goliotto M.
			SOSTITUISCE IL - REPLACES THE N°	FORMATO A4
			SOSTITUITO DAL - REPLACES BY N°	
			N.DISEGNO - N.DRAWING	REV.
			STF047501ST	01