



Centrifugal fan model EUM, Es.4

Single inlet fan, direct driven with an IEC-standard motor in form B3 which is mounted on a motorbase. The overhang impeller is mounted on the motor shaft and has backwardly curved blades. The blades are welded between the back plate disc and the aerodynamically formed front plate. The robust industrial fan is totally made of steel and painted in the agate grey color RAL 7038. The fan is suitable for the transportation of clean and slightly dusty air.

General data:

Drive	direct	
Motor position	horizontal	
Material casing/base	Steel	
Material impeller/hub	Steel	
Coating/protection	RAL 7038	
Operating temperature (max.)	15 (80)	°C
Medium density (altitude 0 m)	1,226	kg/m ³
Impeller speed	1.490	rpm
Weight	1.911	kg
Sound pressure level ±3 (at 1,5 m near the fan with inlet and outlet ducted, in free field)	89	dB(A)

Electric motor:

	315S	IEC
Power	110,0	kW
Motor speed	1.490	rpm
Electric supply	3x400V50Hz	V/Hz
Full load current	193,0	A
Enclosure	55	IP
Shape	B3T	
Efficiency class	IE3	

Curve EUM 1252 @ 1490rpm @ 15°C @ 0m

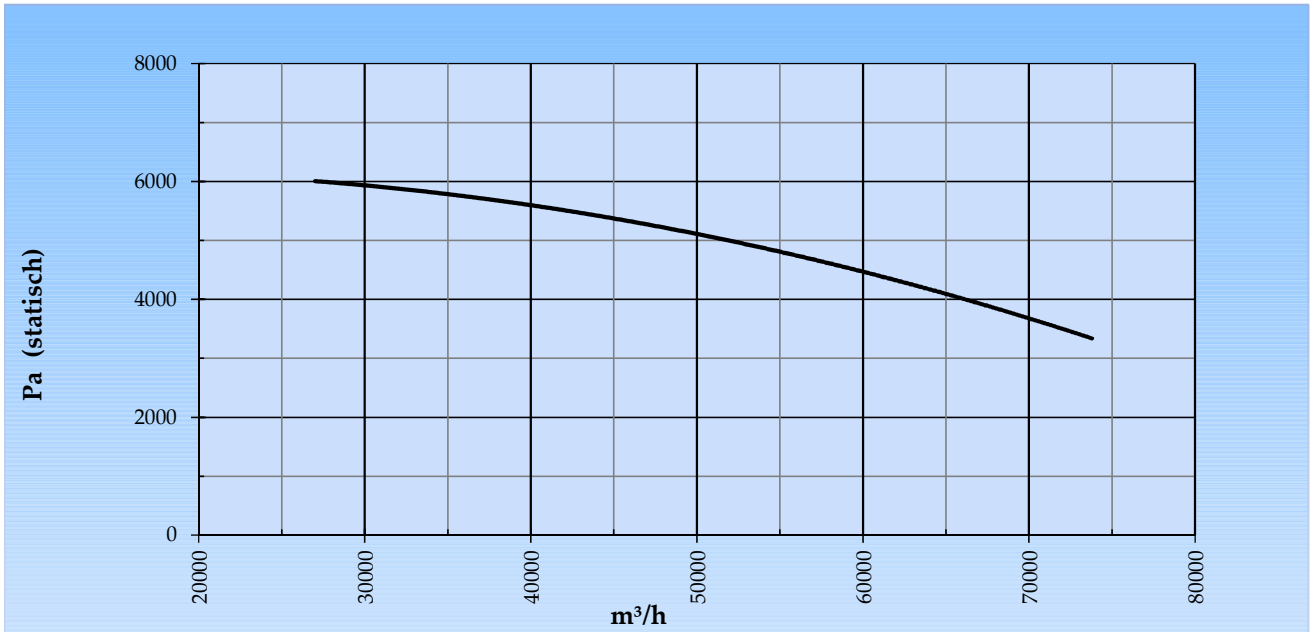

Possible discharge positions:

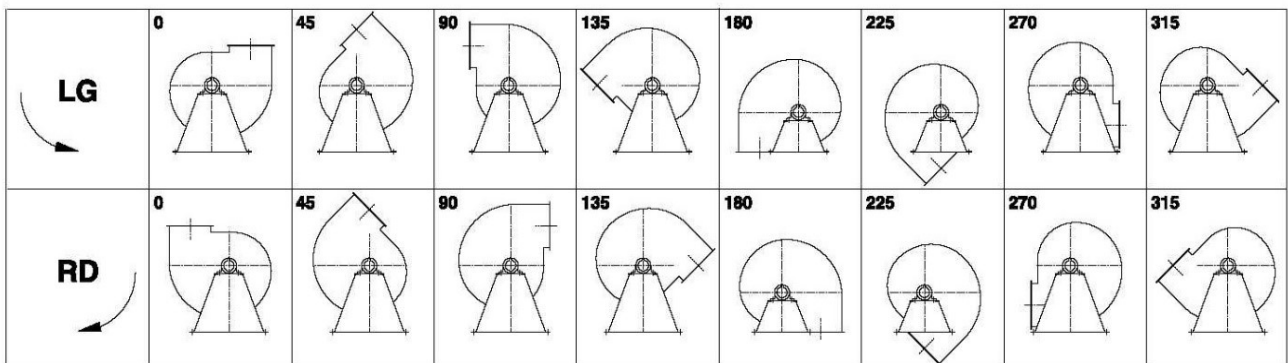

* (Pos 180 and 225 extra price)

Possible accessories

Mounting profiles for load distribution	--
Counterflange inlet/outlet	
Flexible connection inlet/outlet max. 80°C	zz Ø 1120 / pz Ø 1250
Anti-vibration mountings	6x 100x55/B/40°ShA
Inspectiondoor	
Drain	
Shaft seal without asbestos	
Coolingwheel (medium max. 150°C)	(incl. coating RAL9006)
Flexible connection inlet/outlet max. 150°C	zz Ø 1120 / pz Ø 1250
ATEX version	Zone 1 / 2 / 21 / 22
ATEX motor	Ex nA / Exe / Ex de
Coating suitable for outdoor application	RAL 5010 / RAL
Stainless steel version	304 / 316 / ...
Acoustic enclosure	

ES. 4

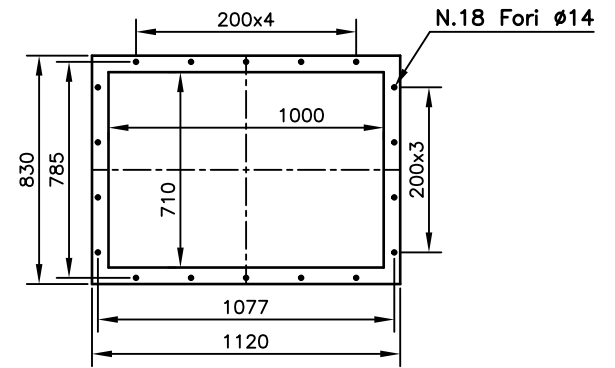
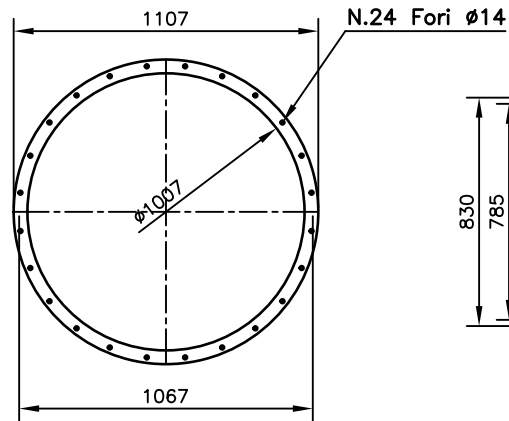
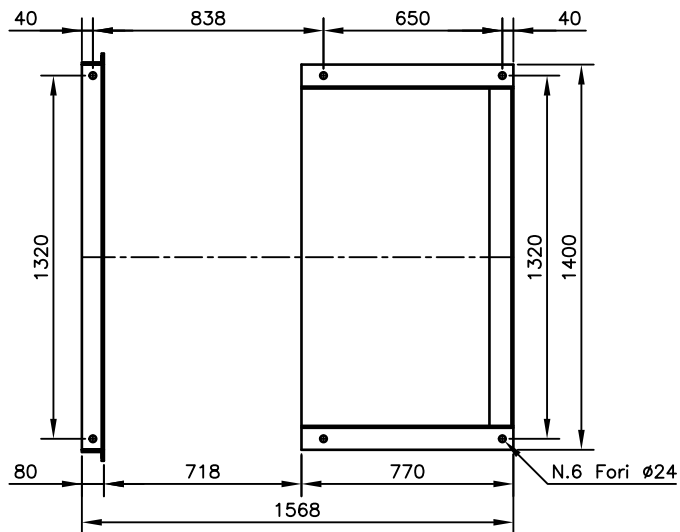
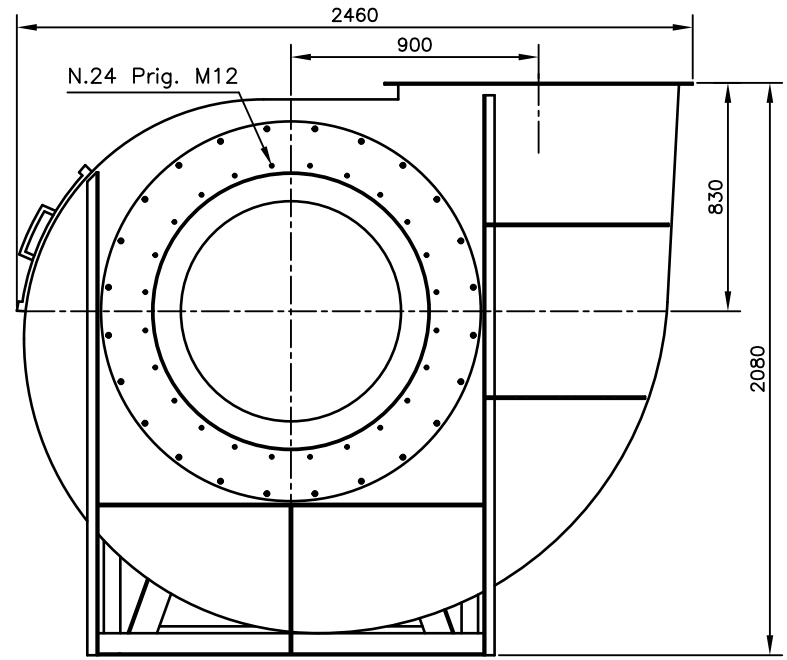
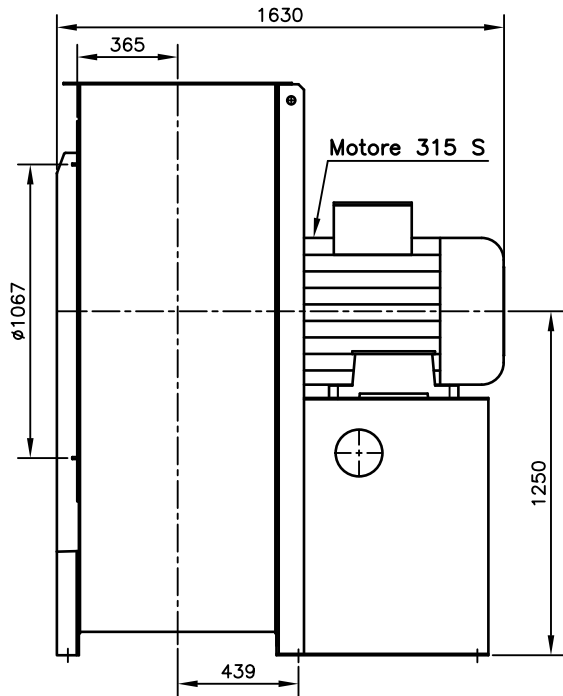

DESCRIZIONE EUM 1252 RDO Es.4 Mot.315 S4	SCALA: 1:26	PESO: kg .	FORMATO: A4
	DATA: .	DISEGNATO: .	
Copy 20-2-2020			