

Centrifugal fan model EU, Es.4

Single inlet fan, direct driven with an IEC-standard motor in form B3 which is mounted on a motorbase. The overhang impeller is mounted on the motor shaft and has backwardly curved blades. The blades are welded between the back plate disc and the aerodynamically formed front plate. The robust industrial fan is totally made of steel and painted in the agate grey color RAL 7038. The fan is suitable for the transportation of clean and slightly dusty air.

General data:

Drive	direct	
Motor position	horizontal	
Material casing/base	Steel	
Material impeller/hub	Steel	
Coating/protection	RAL 7038	
Operating temperature (max.)	15 (80)	°C
Medium density (altitude 0 m)	1,226	kg/m ³
Impeller speed	1.470	rpm
Weight	441	kg
Sound pressure level ±3 (at 1,5 m near the fan with inlet and outlet ducted, in free field)	78	dB(A)

Electric motor:

	160M	IEC
Power	11,0	kW
Motor speed	1.470	rpm
Electric supply	3x400V50Hz	V/Hz
Full load current	20,9	A
Enclosure	55	IP
Shape	B3T	
Efficiency class	IE3	

Curve EU 802 @ 1470rpm @ 15°C @ 0m

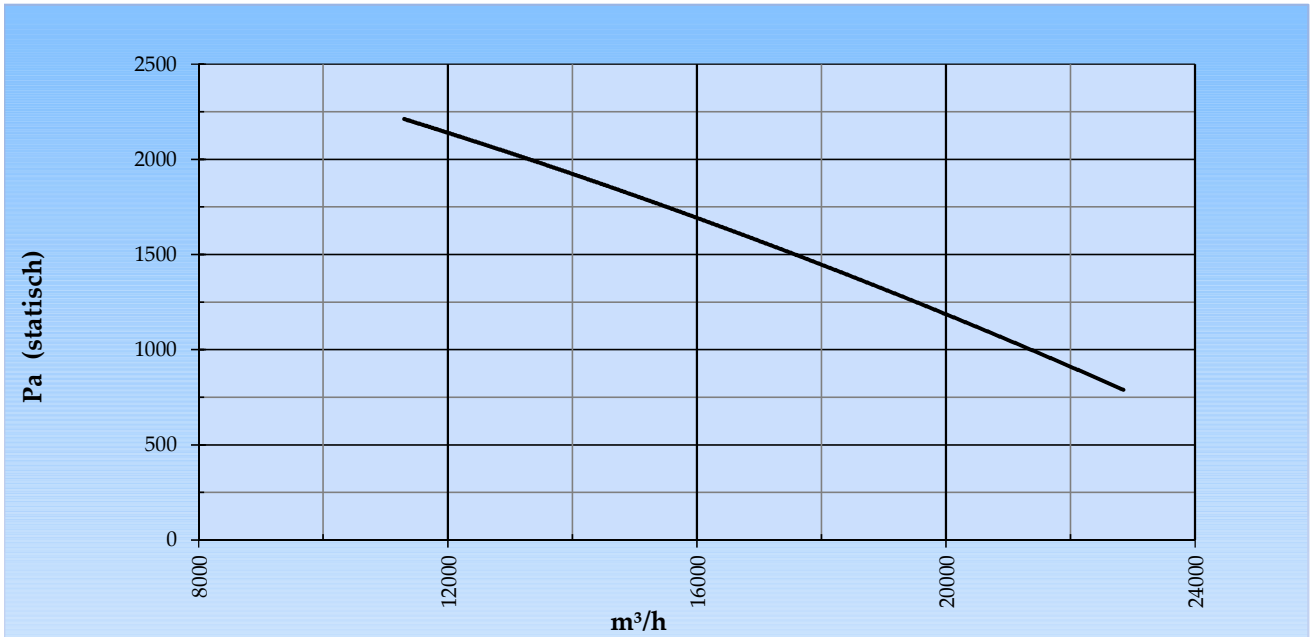

Possible discharge positions:

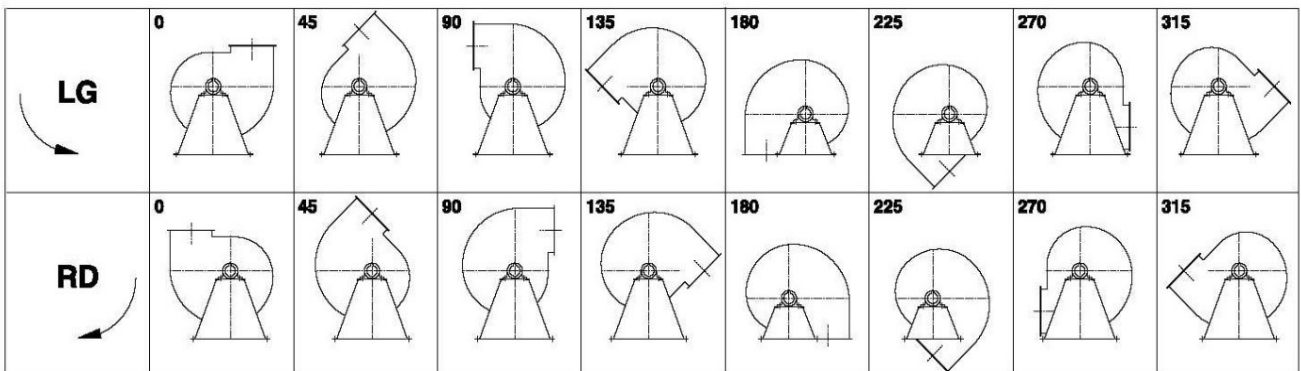

* (Pos 180 and 225 extra price)

Possible accessories

Mounting profiles for load distribution	--
Counterflange inlet/outlet	
Flexible connection inlet/outlet max. 80°C	zzØ 630 / pzØ 800
Anti-vibration mountings	6x 50x40/B/40° ShA
Inspectiondoor	
Drain	
Shaft seal without asbestos	
Coolingwheel (medium max. 150°C)	(incl. coating RAL9006)
Flexible connection inlet/outlet max. 150°C	zzØ 630 / pzØ 800
ATEX version	Zone 1 / 2 / 21 / 22
ATEX motor	Ex nA / Exe / Ex de
Coating suitable for outdoor application	RAL 5010 / RAL
Stainless steel version	304 / 316 / ...
Acoustic enclosure	

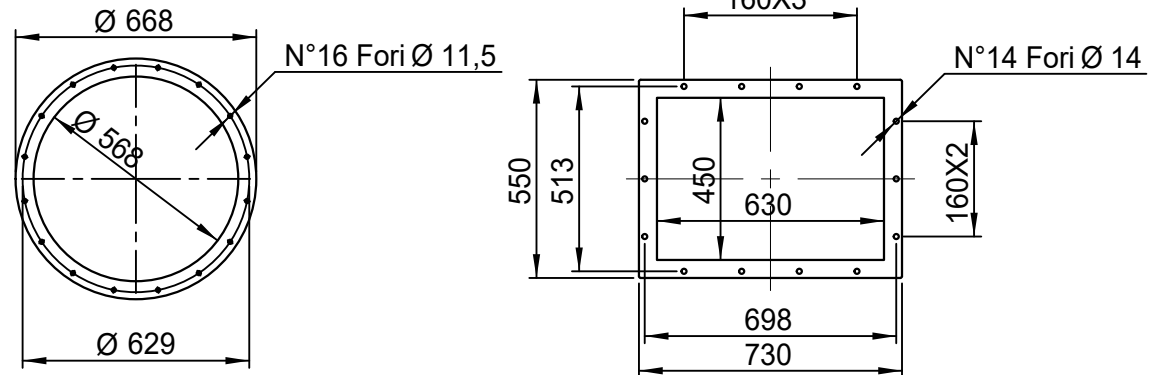
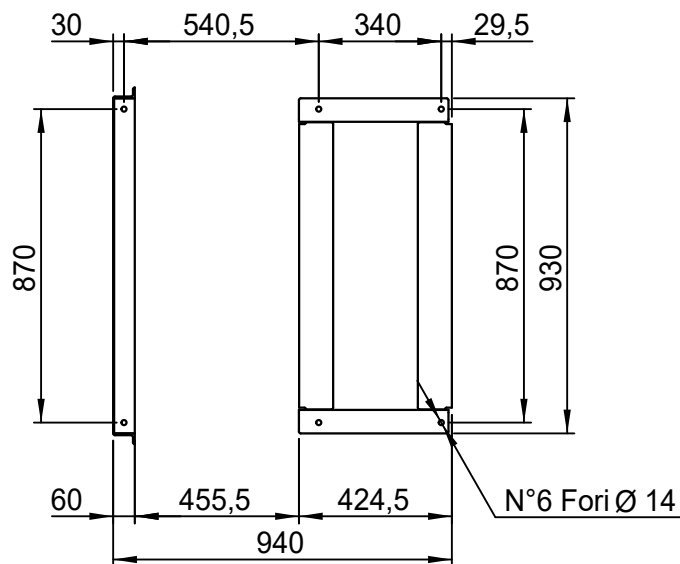
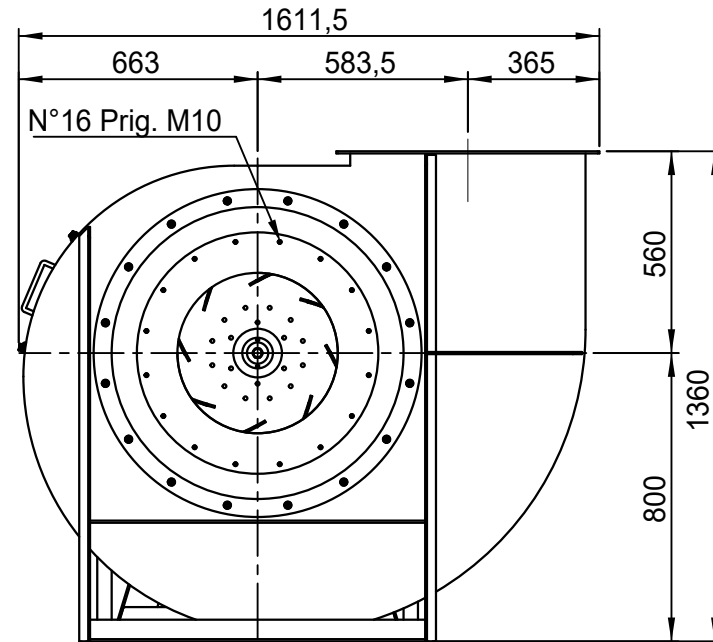
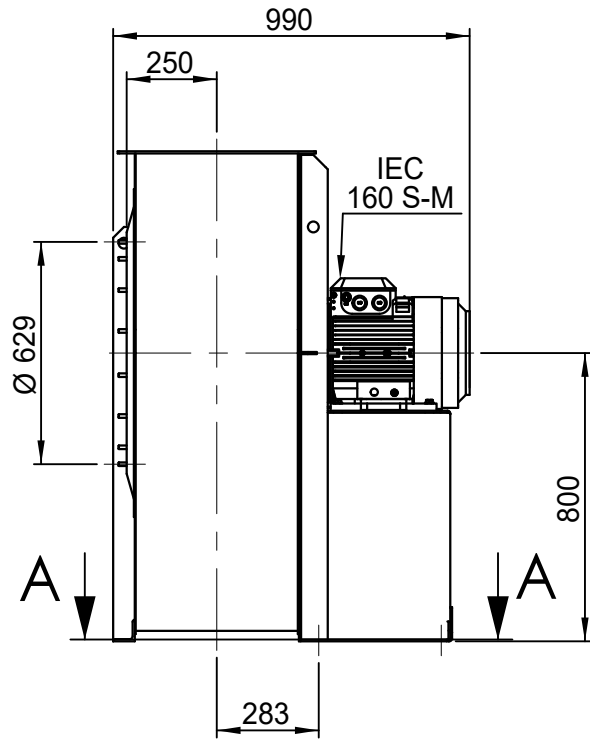

DESCRIZIONE - DESCRIPTION		SCALA 1:20	DISEGNATO - PREPARED	FORMATO
EU 802 - RD 0		DATA 20/01/2015	Cracco S.	A4
		SOSTITUISCE IL - REPLACES THE N° A2EU802A411A000		
		SOSTITUITO DAL - REPLACES BY N°		
Copy 19-2-2020	Slingerland ventilatoren	N.DISEGNO - N.DRAWING		REV.
		V11EU802A0004		00