

Centrifugal fan model EU, Es.4

Single inlet fan, direct driven with an IEC-standard motor in form B3 which is mounted on a motorbase. The overhang impeller is mounted on the motor shaft and has backwardly curved blades. The blades are welded between the back plate disc and the aerodynamically formed front plate. The robust industrial fan is totally made of steel and painted in the agate grey color RAL 7038. The fan is suitable for the transportation of clean and slightly dusty air.

General data:

Drive	direct	
Motor position	horizontal	
Material casing/base	Steel	
Material impeller/hub	Steel	
Coating/protection	RAL 7038	
Operating temperature (max.)	15 (80)	°C
Medium density (altitude 0 m)	1,226	kg/m ³
Impeller speed	2.900	rpm
Weight	97	kg
Sound pressure level ±3 (at 1,5 m near the fan with inlet and outlet ducted, in free field)	77	dB(A)

Electric motor:	112M	IEC
Power	4,0	kW
Motor speed	2.900	rpm
Electric supply	3x400V50Hz	V/Hz
Full load current	7,59	A
Enclosure	55	IP
Shape	B3T	
Efficiency class	IE3	

Curve EU 401 @ 2900rpm @ 15°C @ 0m

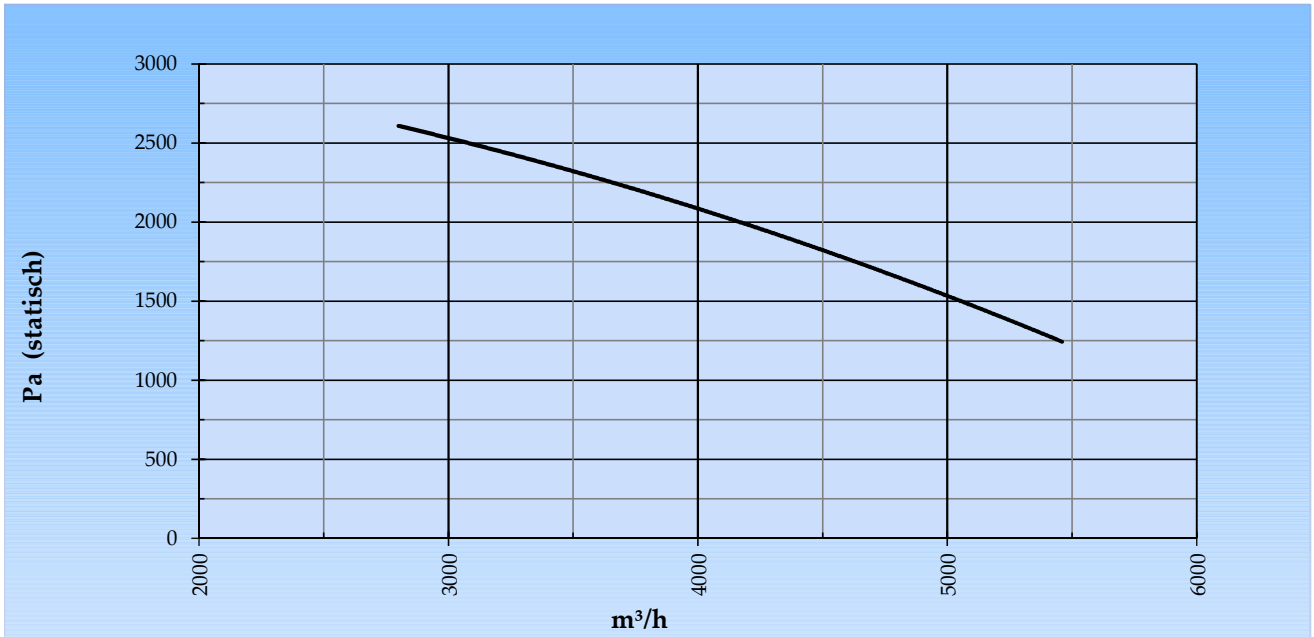

Possible discharge positions:

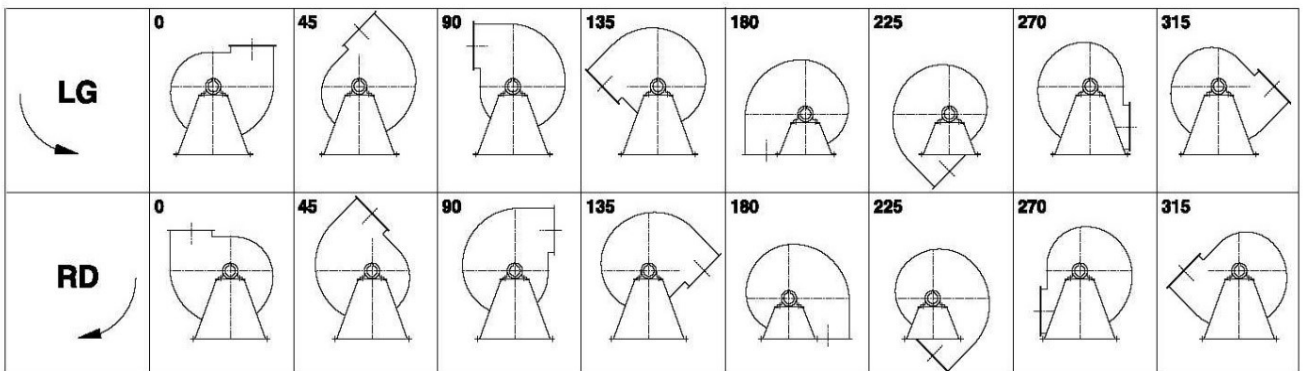

* (Pos 180 and 225 extra price)

Possible accessories

Mounting profiles for load distribution	STF 057501
Counterflange inlet/outlet	
Flexible connection inlet/outlet max. 80°C	zzØ 315 / pzØ 400
Anti-vibration mountings	4x 30x20/B/55° ShA
Inspectiondoor	
Drain	
Shaft seal without asbestos	
Coolingwheel (medium max. 150°C)	(incl. coating RAL9006)
Flexible connection inlet/outlet max. 150°C	zzØ 315 / pzØ 400
ATEX version	Zone 1 / 2 / 21 / 22
ATEX motor	Ex nA / Exe / Ex de
Coating suitable for outdoor application	RAL 5010 / RAL
Stainless steel version	304 / 316 / ...
Acoustic enclosure	

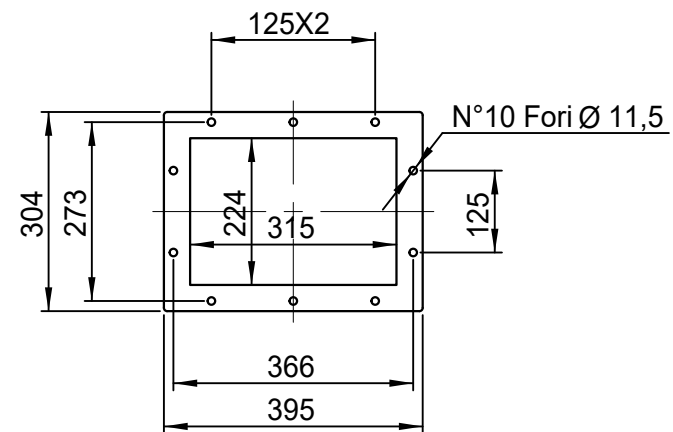
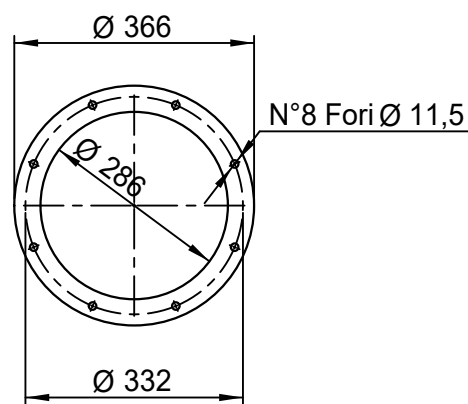
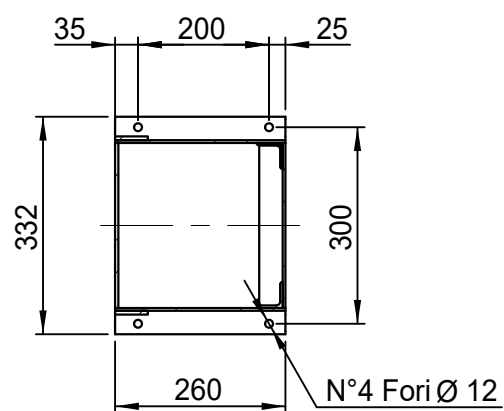
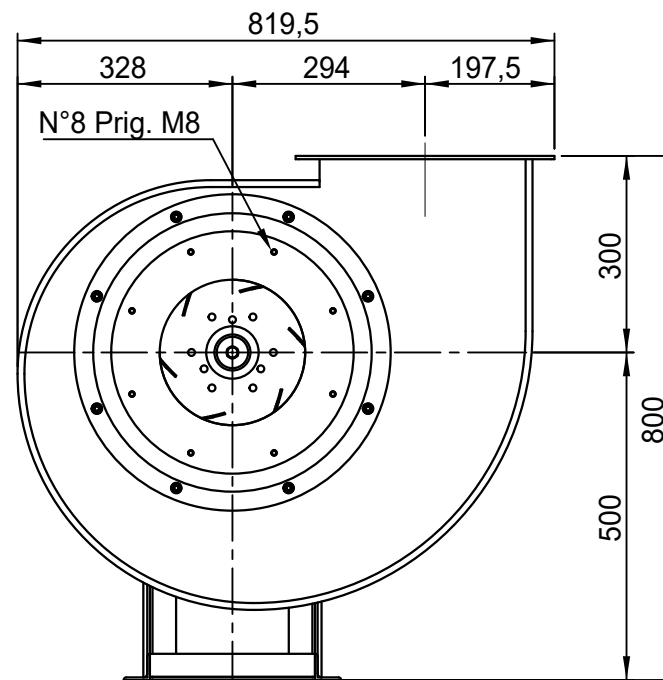
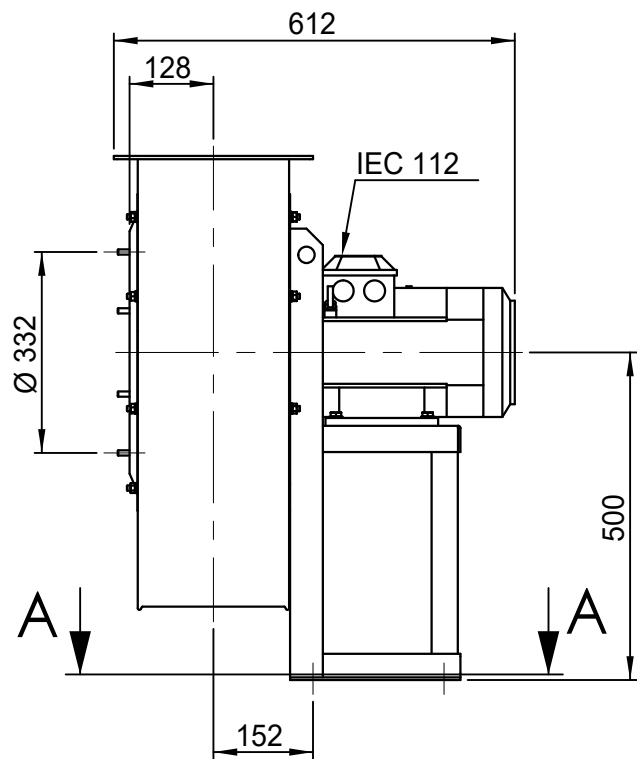

DESCRIZIONE - DESCRIPTION	SCALA	1:11	DISEGNATO - PREPARED	FORMATO
	DATA	17/12/2014	Cracco S.	A4
EU 401 - RD 0	SOSTITUISCE IL - REPLACED THE N° A2EU401A411A000			
	SOSTITUITO DAL - REPLACES BY N°			
Copy 8-7-2020	N.DISEGNO - N.DRAWING			REV.
Slingerland ventilatoren		V11EU401A0022		00

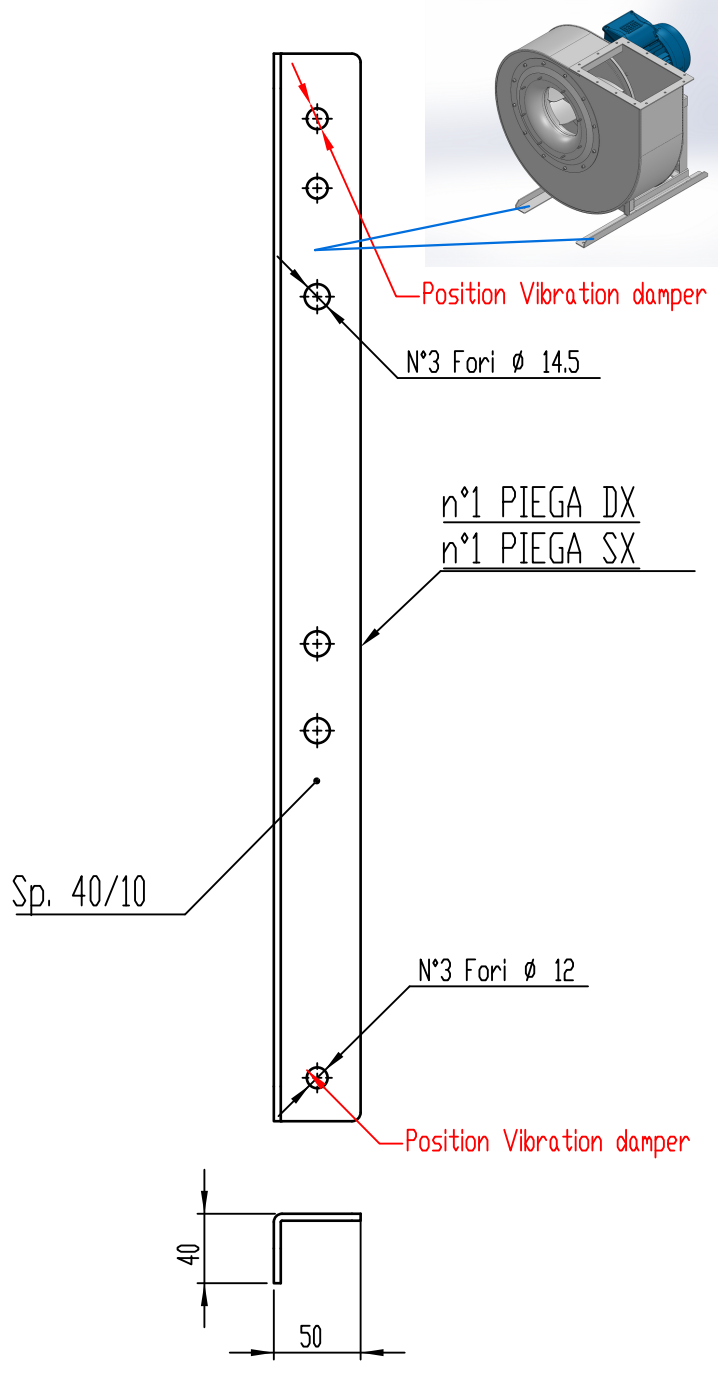
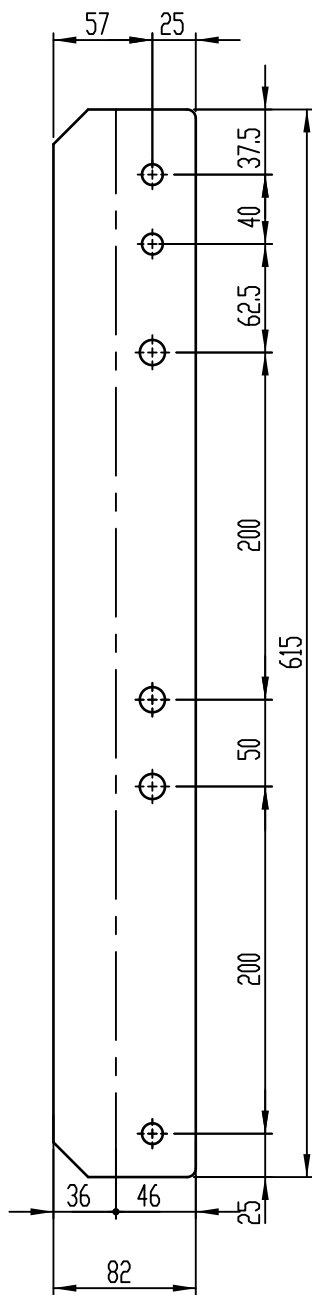

COMM.
N°

01	04/12/2019	Adattamento alle sedie nuove	Galiotto M.	De Santi G.
00	23/11/2015	PRIMA EMISSIONE	Galiotto M.	De Santi G.
REV	DATA - DATE	DESCRIZIONE - DESCRIPTION	DISEGNATO PREPARED	CONTROLLATO CHECKED
DESCRIZIONE - DESCRIPTION		MATERIALE - MATERIAL	NR.FILE	PESO - WEIGHT
Staffe per Puffer L=615 IEC 100-112-132		Fe 360	EUR00067997	Kg 1.53
		SCALA 1:4	DISEGNATO - PREPARED	FORMATO
		DATA 04/12/2019	Galiotto M.	A4
		SOSTITUISCE IL - REPLACES THE N° SOSTITUITO DAL - REPLACES BY N°		
N.DISEGNO - N.DRAWING			REV.	
STF057501			01	

