



Axial wall fan model AW EC.

The free-running impeller is made of high-quality composite material and has a bionically designed blade geometry. It is powered by a highly efficient external rotor motor.

This fan has a high efficiency, excellent noise level and is maintenance-free and reliable. It is made of galvanized steel and then powder coated black (RAL9005). Supplied with protective grille (sizes 200-630), for larger models (sizes 710-1000) it is an accessory.

100% adjustable via a 0-10V signal. And the motor protection is integrated in the motor electronics.

General data:

Max Air flow	3.179	m ³ /h
Impeller speed	2.245	rpm
Input power	167	W
Voltage (nominal)	1x230/50/60	V/Hz
Input current	1,36	A
Enclosure class, motor	54	IP
Weight	5	kg
Max. Temperature of transported air	60	°C
Max. temperature of transported air, when speed controlled	60	°C
Sound pressure level ±2*	59	dB(A)

**(at 1,5 m near the fan with inlet and outlet ducted, in free field)*

Options:

Louvre shutter, plastic	VK 300
five-step transformer	Potentiometer 1x230V supplied externally
MTP	Potentiometer 10V powered by fan

Curve :

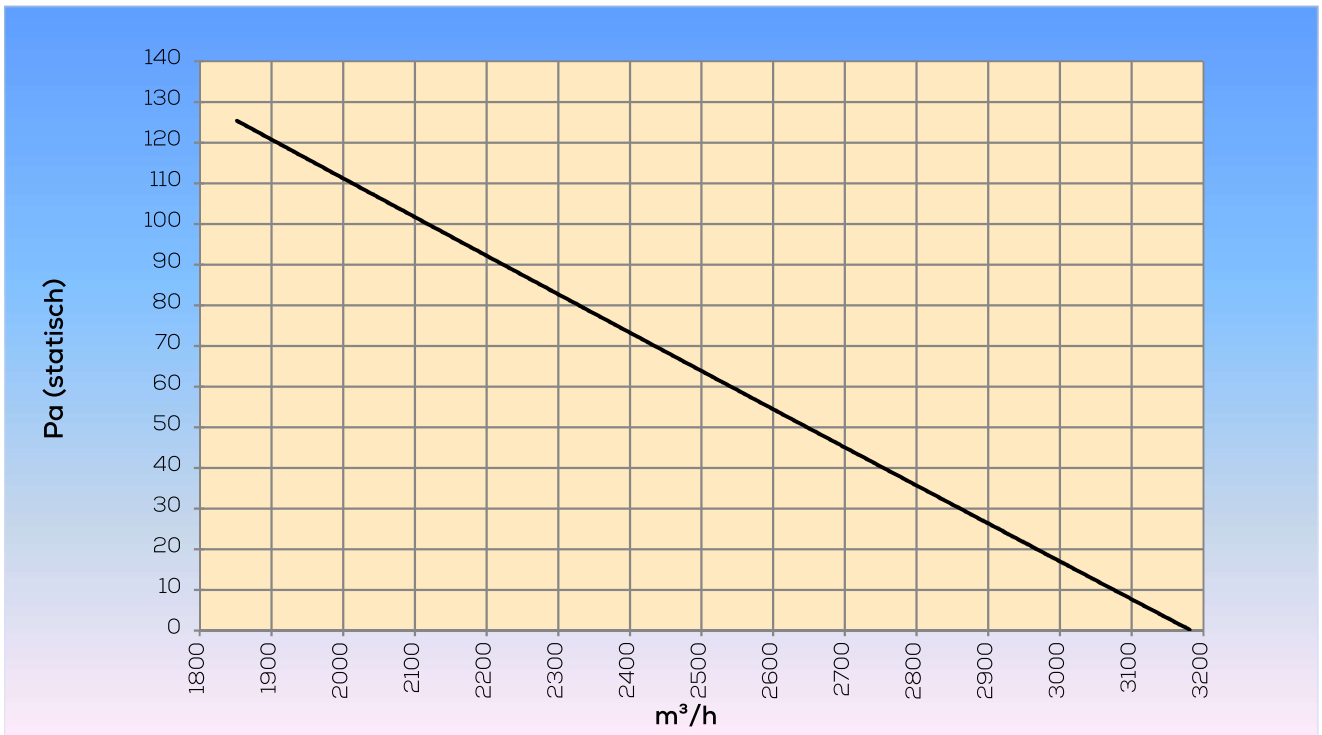

Dimensions:

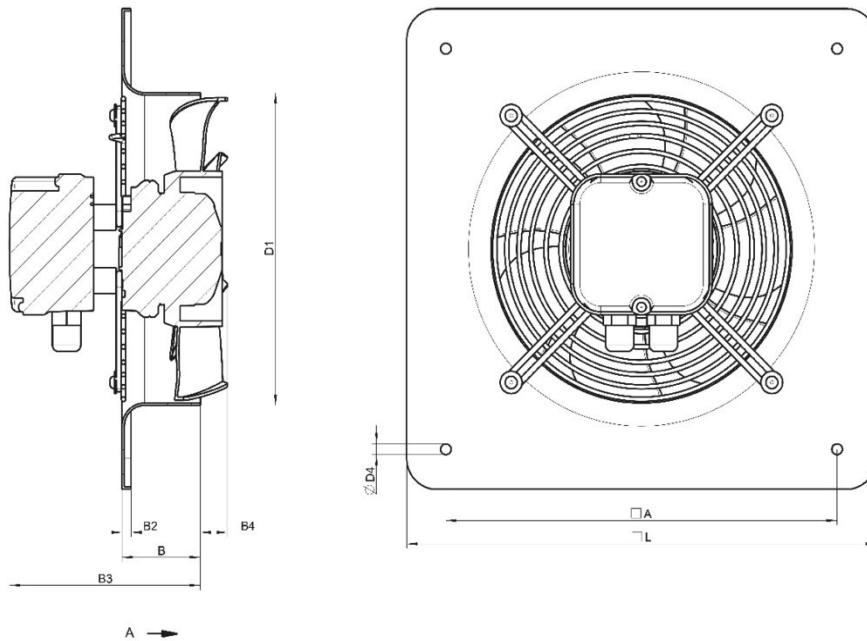

□A	B	B2	B3	B4	ØD1	ØD4	□L
380	80	11	157	11	327	9	430