

Centrifugal fan model APF Es.4

Single inlet fan, direct driven with an IEC-standard motor in form B3 which is mounted on a motorbase. The overhang impeller is mounted on the motor shaft and has forward curved blades. The blades are welded between the back plate disc and the aerodynamically formed front plate. The fans of this series are particularly suitable for pneumatic conveyances, in cement factories, in the air feeding of the cupolas, in foundries and in oil burners, in mills, in "pasta" factories, in chemical, metallurgical and iron industries where small capacities with medium and high pressures are required.

General data:

Drive	direct	
Motor position	horizontal	
Material casing/base	Steel	
Material impeller/hub	Steel	
Coating/protection	RAL 7038	
Operating temperature (max.)	15 (80)	°C
Medium density (altitude 0 m)	1,226	kg/m ³
Impeller speed	2.900	rpm
Weight	107	kg
Sound pressure level ±3 (at 1,5 m near the fan with inlet and outlet ducted, in free field)	79	dB(A)

Electric motor:

	112M	IEC
Power	4,0	kW
Motor speed	2.900	rpm
Electric supply	3x400V50Hz	V/Hz
Full load current	7,59	A
Enclosure	55	IP
Shape	B3T	
Efficiency class	IE3	

Curve APF 561A @ 2900rpm @ 15°C @ 0m

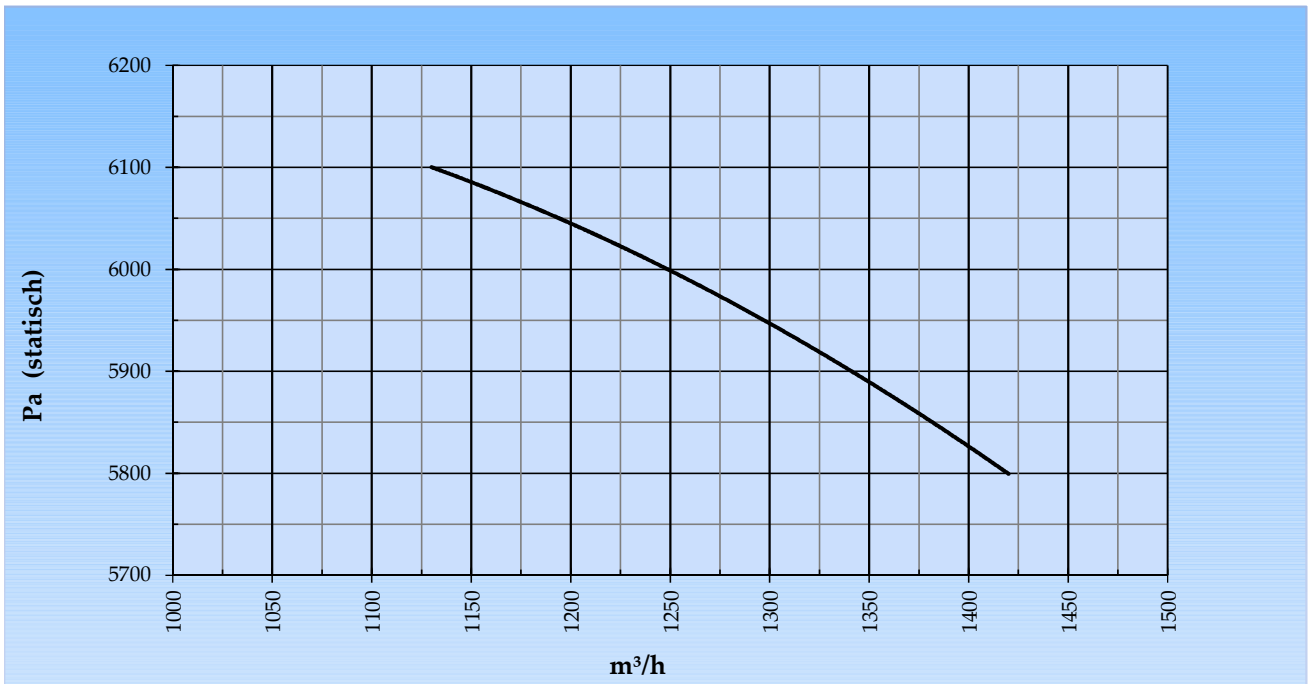

Possible discharge positions:

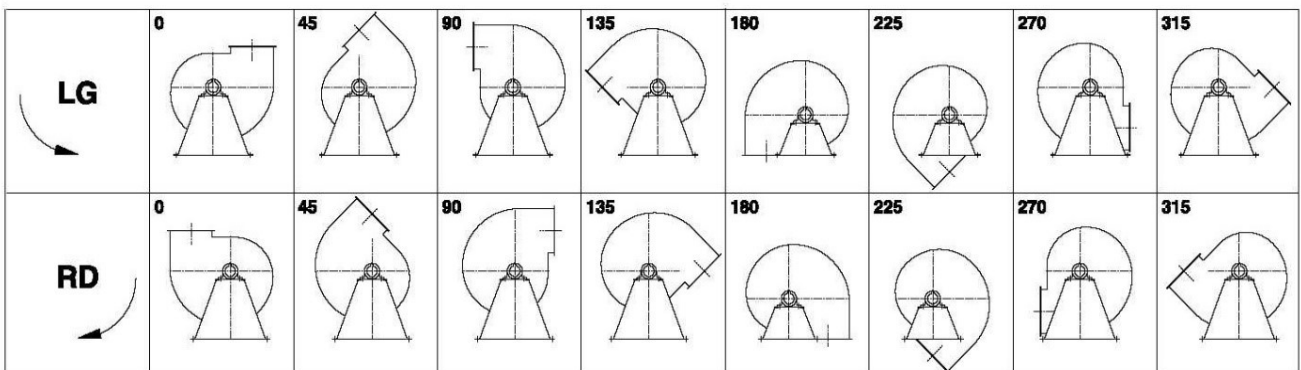

* (Pos 180 and 225 extra price)

Possible accessories

Mounting profiles for load distribution	STF AP10011201ST
Counterflange inlet/outlet	
Flexible connection inlet/outlet max. 80°C	zzØ 200 / pz Ø200
Anti-vibration mountings	4x 30x20/B/55° ShA
Inspectiondoor	
Drain connection	
Shaft seal without asbestos	
Coolingwheel (medium max. 150°C)	(incl. coating RAL9006)
Flexible connection inlet/outlet max. 150°C	zzØ 200 / pz Ø200
ATEX version	Zone 1 / 2 / 21 / 22
ATEX motor	Ex nA / Exe / Ex de
Coating suitable for outdoor application	RAL 5010 / RAL ...
Stainless steel version	304 / 316 / ...
Acoustic enclosure	

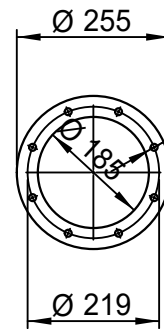
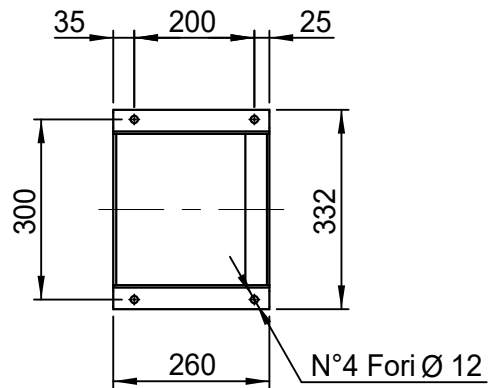
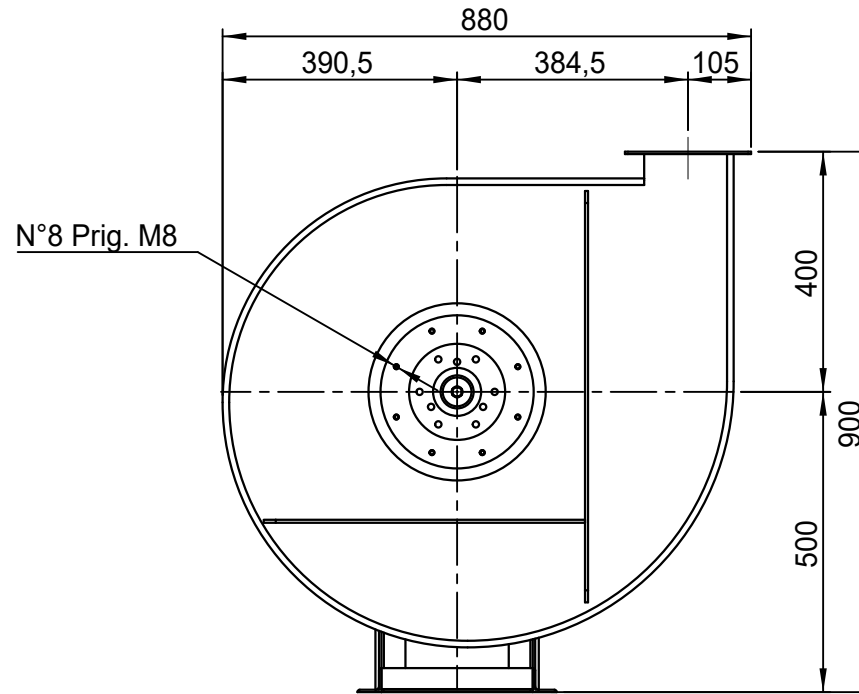
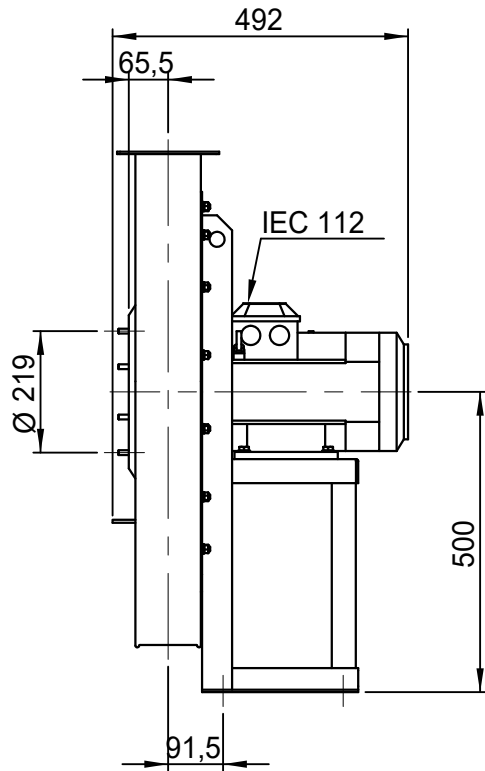

N°8 Fori Ø 11,5

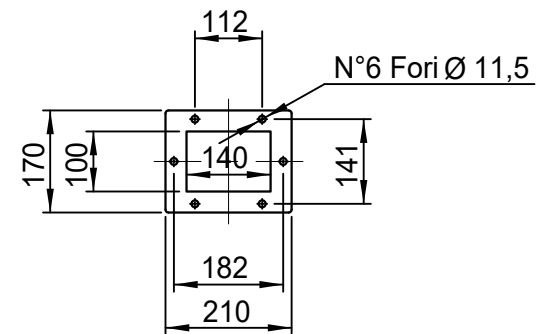

DESCRIZIONE - DESCRIPTION	SCALA 1:12	DISGNATO - PREPARED	FORMATO
	DATA 16/02/2015	Duregotti P.	A4
APF 561/A - RD 0			
SOSTITUISCE IL - REPLACED THE N° AAPF561A411A000		SOSTITUITO DAL - REPLACES BY N°	
Copy 29-6-2020	N.DISEGNO - N.DRAWING	REV.	
		V1APF561A0004	00

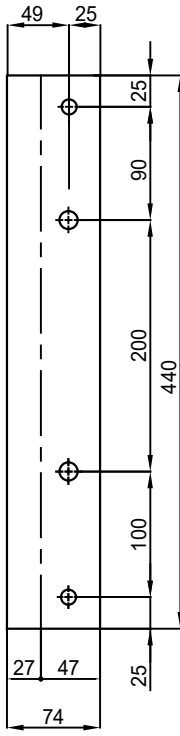

Sp. 30/10

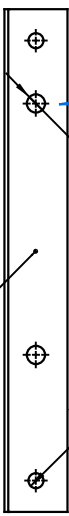
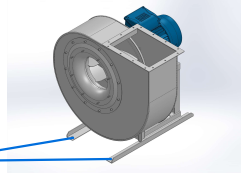

n°1 PIEGA DX
n°1 PIEGA SX

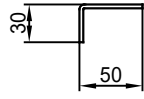

COMM.
N°

00	02/02/2016	PRIMA EMISSIONE		RK	RK
01	16/09/2020	Extention pedestal		MvS	MvS
REV	DATA - DATE	DESCRIZIONE - DESCRIPTION		DISEGNATO PREPARED	CONTROLLATO CHECKED
DESCRIZIONE - DESCRIPTION		MATERIALE - MATERIAL	NR.FILE	PESO - WEIGHT	
		Fe 360		Kg	
DESCRIZIONE - DESCRIPTION			SCALA 1:4	DISEGNATO - PREPARED	FORMATO
Staffe per Puffer L=440 IEC 100-112 / AP series			DATA 02/02/2016	RK	A4
			SOSTITUISCE IL - REPLACED THE N° SOSTITUITO DAL - REPLACES BY N°		
N.DISEGNO - N.DRAWING				REV.	
STF-AP10011201ST				01	

