

APRH 801A

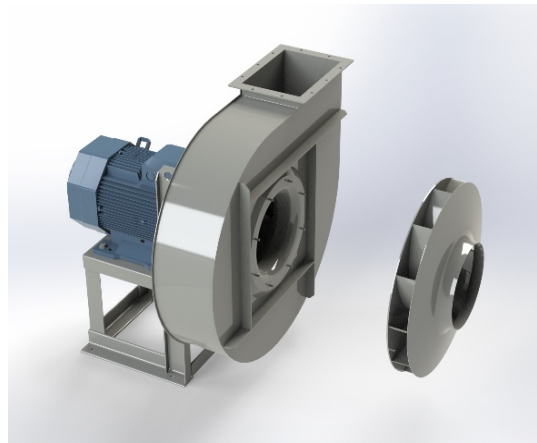

Centrifugal fan model APRH, Es.4

Single inlet fan, direct driven with an IEC-standard motor in form B3 which is mounted on a motorbase. This series of high-pressure fans is characterized by a high efficiency with electricity saving by installing a special impeller with backward curved blades. The robust industrial fan is totally made of steel and painted in the agate gray RAL 7037. The fan is suitable for the transportation of clean and slightly dusty air.

General data:

Drive	direct
Motor position	horizontal
Material casing/base	Steel
Material impeller/hub	Steel
Motorcoating/protection	RAL 7037
Operating temperature (max.)	15 (80) °C
Medium density (altitude 0 m)	1,226 kg/m ³
Impeller speed	2960 rpm
Weight	730 kg
Sound pressure level ±3	94 dB(A)

(at 1,5 m near the fan with inlet and outlet ducted, in free field)

Electric motor:

	250M	IEC
Power	55	kW
Motor speed	2.960	rpm
Electric supply	3x400V50Hz	V/Hz
Full load current	95,6	A
Enclosure	55	IP
Shape	B3T	
Efficiency class	IE3	

Curve APRF 1121D @ 1470rpm @ 15°C @ 0m

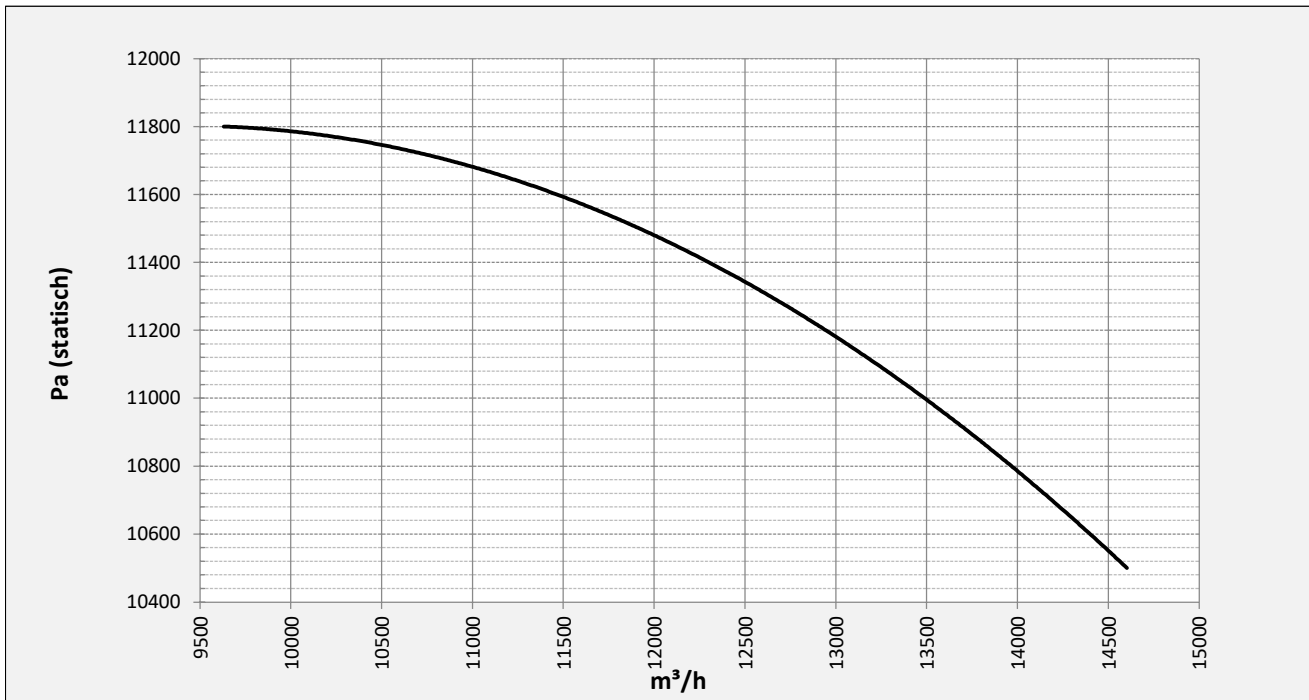

Possible discharge positions:



* (Pos 180 and 225 extra price)

Possible accessories

Mounting profiles for load distribution	--
Counterflange inlet/outlet	zz Ø400 / pz 400x280
Flexible connection inlet/outlet max. 80°C	zz Ø450 / pz Ø500
Anti-vibration mountings	4x 70X45/B/70° ShA
Inspectiondoor	
Drain connection	
Shaft seal without asbestos	
Coolingwheel (medium max. 150°C)	(incl. coating RAL9006)
Flexible connection inlet/outlet max. 150°C	zz Ø450 / pz Ø500
ATEX version	Zone 1 / 2 / 21 / 22
ATEX motor	Ex nA / Exe / Ex de
Coating suitable for outdoor application	RAL 5010 / RAL
Stainless steel version	304 / 316 / ...
Acoustic enclosure	

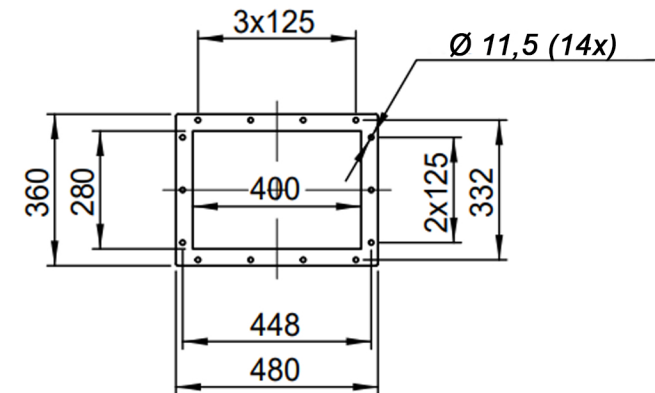
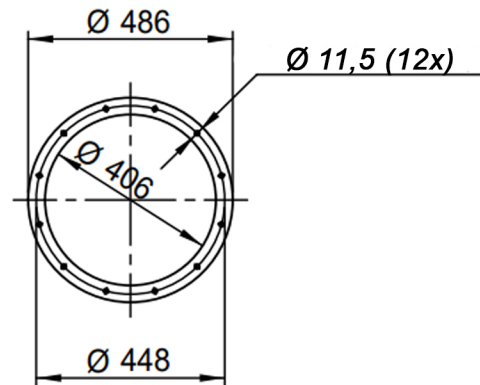
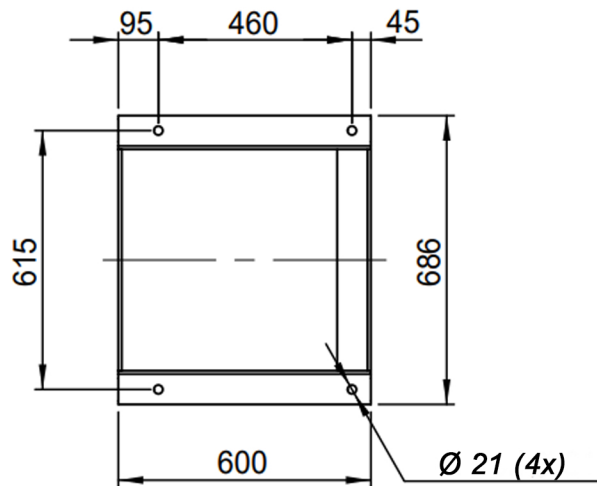
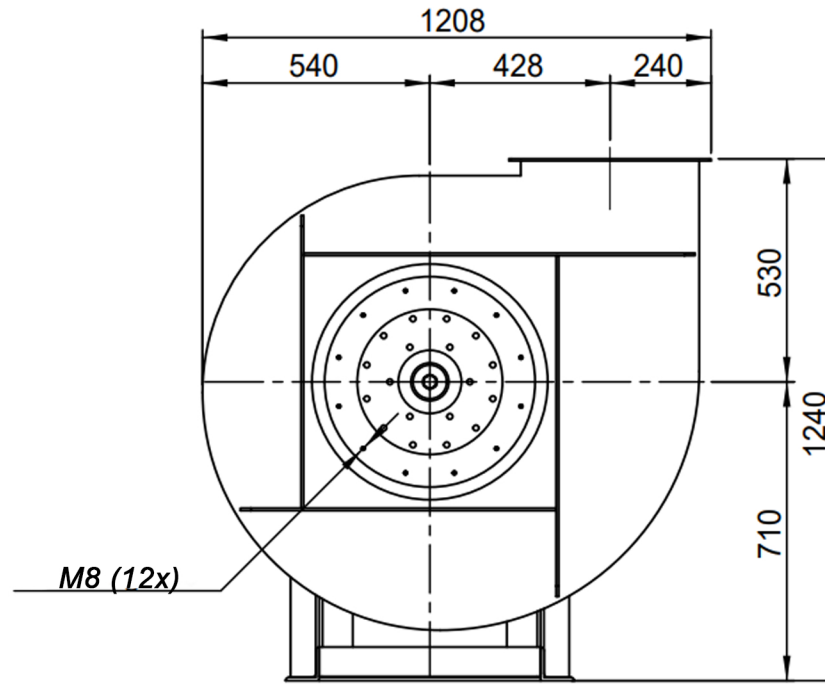
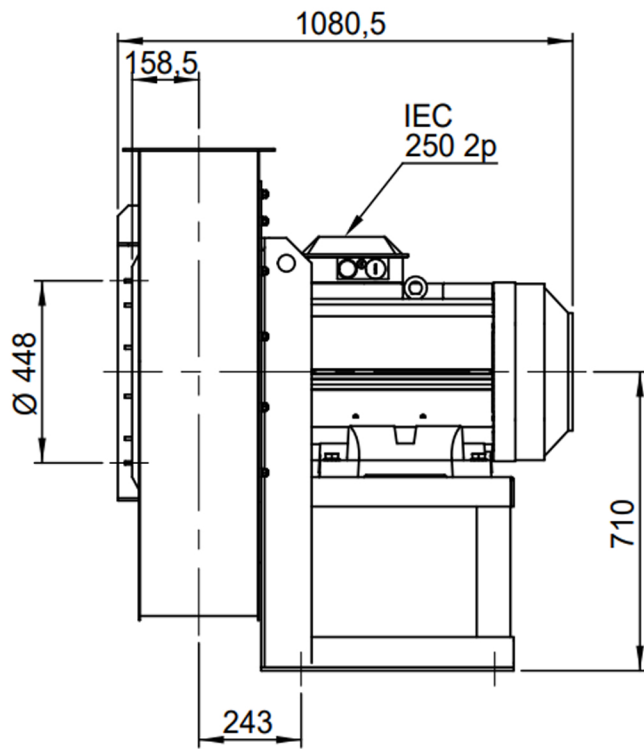

DESCRIPTION-BESCHRIJVING APRH801/A - RD0	SCHAAL 1:18	GEMAAKT - PREPARED Overmeer E.	FORMAAT A4
	DATUM 22/11/2023		
Slingerland ventilatoren		N.TEKENING - N.DRAWING	
		V1APRH801/A	
			REV. 00