

8300100101
VBH0560CTTRS

EC centrifugal module - RadiPac

backward-curved, single-intake
with support bracket



Nominal data

Item	8300100101	
Motor	E15034-120	
Phase		3~
Nominal voltage	VAC	400
Nominal voltage range	VAC	380 .. 480
Frequency	Hz	50/60
Method of obtaining data		ml
Status		prelim.
Speed (rpm)	min ⁻¹	2370
Power consumption	W	6500
Current draw	A	10
Min. ambient temperature	°C	-40
Max. ambient temperature	°C	40

ml = Max. load · me = Max. efficiency · fa = Free air · cs = Customer specification · ce = Customer equipment
Subject to change

Data according to Commission Regulation (EU) 327/2011 (prEN 17166)

		Actual	Req. 2015			
01 Overall efficiency η_{es}	%	75.5	59.9	09 Power consumption P_{ed}	kW	6.32
02 Measurement category		A		09 Air flow q_v	m ³ /h	14165
03 Efficiency category		Static		09 Pressure increase p_{fs}	Pa	1172
04 Efficiency grade N		77.6	62	10 Speed (rpm) n	min ⁻¹	2370
05 Variable speed drive		Yes		11 Specific ratio*		1.01

Data obtained at optimum efficiency level.

* Specific ratio = $1 + p_{fs} / 100\,000$ Pa

LU-215301

The efficiency values displayed for achieving conformity with the Ecodesign Regulation EU 327/2011 has been reached with defined air duct components (e.g. inlet rings).
The dimensions must be requested from ebm-papst. If other air conduction geometries are used on the installation side, the ebm-papst evaluation loses its validity/the conformity must be confirmed again.
The product does not fall within the scope of Regulation (EU) 2019/1781 due to the exception specified in Article 2 (2a) (motors completely integrated into a product).



8300100101

VBH0560CTTRS

EC centrifugal module - RadiPac

backward-curved, single-intake
with support bracket



Technical description

Size	560 mm
Motor size	150
Rotor surface	Painted black
Electronics housing material	Die-cast aluminum
Impeller material	PP plastic
Support plate material	Sheet steel, galvanized
Support bracket material	Steel, painted black
Inlet nozzle material	ABS plastic
Number of blades	5
Direction of rotation	Clockwise, viewed toward rotor
Degree of protection	IP55
Insulation class	"F"
Moisture (F) / Environmental (H) protection class	H1
Ambient temperature note	Occasional start-up at temperatures between -40°C and -25°C is permitted. For continuous operation at ambient temperatures below -25°C (such as refrigeration applications), use must be made of a fan design with special low-temperature bearings.
Max. permitted ambient temp. for motor (transport/storage)	+80 °C
Min. permitted ambient temp. for motor (transport/storage)	-40 °C
Installation position	See legend on product drawing
Condensation drainage holes	On rotor side
Mode	S1
Motor bearing	Ball bearing
Technical features	<ul style="list-style-type: none"> - Operation and alarm display with LED - External 15-50 VDC input (parameterization) - Alarm relay - Integrated PI controller - Configurable inputs/outputs (I/O) - MODBUS V6.3 - Motor current limitation - RS-485 MODBUS-RTU - Soft start - Voltage output 3.3-24 VDC, Pmax = 800 mW - Control interface with SELV potential safely disconnected from the mains - Thermal overload protection for electronics/motor - Line undervoltage / phase failure detection - Vibration sensor
Touch current according to IEC 60990 (measuring circuit Fig. 4, TN system)	<= 3.5 mA
Electrical hookup	Terminal box
Motor protection	Electronic motor protection
Protection class assignment	<p>I; If a protective earth is connected by the customer</p> <p>This component for installation may have several local protection classes. This information relates to this component's basic design.</p> <p>The final protection class is based on the component's intended installation and connection.</p>
Conformity with standards	EN 61800-5-1; UKCA; CE



8300100101
VBH0560CTTRS

EC centrifugal module - RadiPac

backward-curved, single-intake
with support bracket



Approval

UL 1004-7 + 60730-1; CSA C22.2 No. 77 + CAN/CSA-E60730-1; EAC



ebmpapst

8300100101
VBH0560CTTRS

EC centrifugal module - RadiPac

backward-curved, single-intake
with support bracket



Product drawing

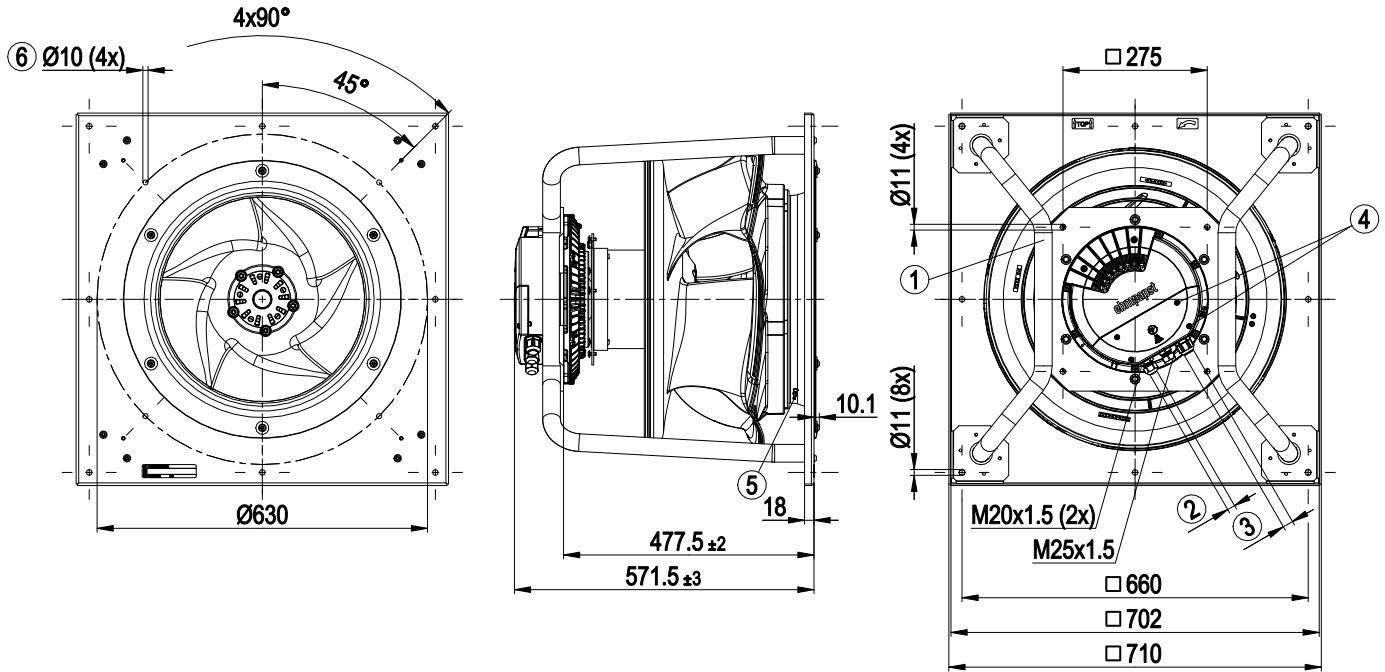

1	Installed position: shaft horizontal (install support struts only vertically as illustrated) or rotor on bottom; rotor on top on request
2	Cable diameter min. 4 mm, max. 10 mm, tightening torque 4 ± 0.6 Nm
3	Cable diameter min. 5 mm, max. 14 mm, tightening torque 6 ± 0.9 Nm
	(The tightening torque is designed for PVC cables. If the cable materials are different, the tightening torque may have to be adjusted)
4	Tightening torque 3 ± 0.3 Nm
5	Inlet ring with pressure tap (k-factor: 381)
6	Attachment holes for FlowGrid 50710-2-2957 (not included in scope of delivery)



Connection diagram

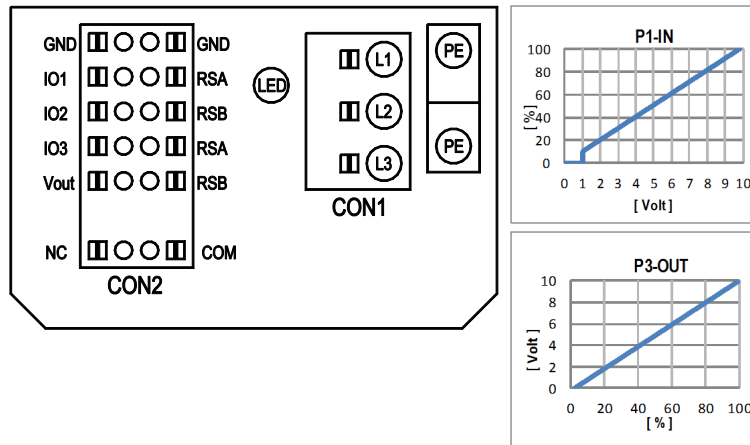

No.	Conn.	Designation	Function/assignment
	CON1	L1, L2, L3	Power supply, phase, see nameplate for voltage range
	PE	PE	Protective earth
	CON2	RSA	RS485 interface for MODBUS, RSA; SELV
	CON2	RSB	RS485 interface for MODBUS, RSB; SELV
	CON2	GND	Reference ground for control interface, SELV
	CON2	IO1	Function parameterizable (see "Optional interface functions" table) Factory setting: Digital input - high active, function: Disable input, SELV - inactive: Pin open or applied voltage < 1.5 VDC - active: applied voltage 3.5-50 VDC Reset function: Triggering of error reset on change of state from "enabled" to "disabled"
	CON2	IO2	Function parameterizable (see "Optional interface functions" table) Factory setting: Analog input 0-10 V/PWM, Ri=100 kΩ, function: Set value Characteristic curve parameterizable (see input characteristic curve P1-IN), SELV
	CON2	IO3	Function parameterizable (see "Optional interface functions" table) Factory setting: Analog output 0-10 V, max. 5 mA, function: Actual speed Characteristic curve parametrizable (see output characteristic curve P3-OUT), SELV
	CON2	Vout	Voltage output 3.3-24 VDC ±5%, Pmax=800 mW, voltage parameterizable Factory setting: 10 VDC short-circuit-proof, supply for external devices, SELV alternatively: 15-50 VDC input for parameterization via MODBUS without line voltage
	CON2	COM	Status relay, floating status contact, common connection, contact rating 250 VAC / 2 A (AC1) / min. 10 mA, reinforced insulation on supply side and on control interface side
	CON2	NC	Status relay, floating status contact, break for failure
		LED	green: status = good, ready for operation orange: status = warning red: status = failure
		P1-IN	Input characteristic curve
		P3-OUT	Output characteristic curve

8300100101

VBH0560CTTRS

EC centrifugal module - RadiPac

backward-curved, single-intake
with support bracket



Curves: Air performance 50 Hz

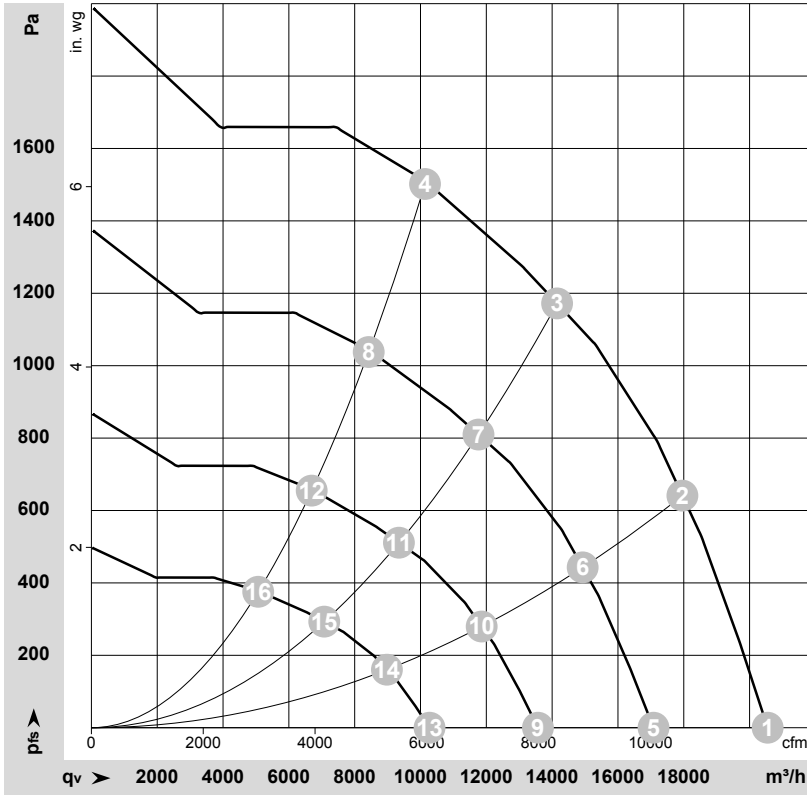

$\rho = 1.15 \text{ kg/m}^3 \pm 2 \%$

Measurement: LU-215301-1

Air performance measured according to ISO 5801 installation category A. For detailed information on the measurement setup, contact ebmpapst. Intake sound level: Sound power level according to ISO 13347 / sound pressure level measured at 1 m distance from fan axis. The values given are valid under the specified measuring conditions and may vary due to conditions of installation. For deviations from the standard configuration, the parameters have to be checked on the installed unit.

Measured values

	Wired	U	f	n	P _e	I	LpA _{in}	LwA _{in}	LwA _{out}	q _v	P _{fs}	q _v	P _{fs}
		V	Hz	min ⁻¹	W	A	dB(A)	dB(A)	dB(A)	m ³ /h	Pa	cfm	in. wg
1	3~	400	50	2370	4000	6.28	87	95	98	20550	0	12095	0.00
2	3~	400	50	2370	5645	8.72	82	89	93	17960	640	10570	2.57
3	3~	400	50	2370	6500	10.00	77	84	89	14150	1170	8330	4.70
4	3~	400	50	2370	6305	9.68	79	85	90	10140	1510	5970	6.06
5	3~	400	50	1970	2298	3.60	83	91	94	17080	0	10055	0.00
6	3~	400	50	1970	3243	5.01	77	85	88	14930	443	8785	1.78
7	3~	400	50	1970	3630	5.57	72	80	84	11765	810	6925	3.25
8	3~	400	50	1970	3622	5.56	74	80	86	8425	1044	4960	4.19
9	3~	400	50	1565	1152	1.81	77	85	88	13570	0	7985	0.00
10	3~	400	50	1565	1626	2.51	71	79	82	11860	280	6980	1.12
11	3~	400	50	1565	1820	2.79	66	74	78	9345	511	5500	2.05
12	3~	400	50	1565	1816	2.79	68	74	80	6695	659	3940	2.65
13	3~	400	50	1185	500	0.78	70	78	81	10275	0	6050	0.00
14	3~	400	50	1185	706	1.09	64	72	75	8980	160	5285	0.64
15	3~	400	50	1185	790	1.21	59	67	71	7075	293	4165	1.18
16	3~	400	50	1185	788	1.21	61	67	73	5070	378	2985	1.52

Wired = Wiring · U = Voltage · f = Frequency · n = Speed (rpm) · P_e = Power consumption · I = Current draw · LpA_{in} = Sound pressure level intake side · LwA_{in} = Sound power level intake side
LwA_{out} = Sound power level outlet side · q_v = Air flow · P_{fs} = Pressure increase



ebmpapst