

8300100104
VBH0310CTRLS

EC centrifugal module - RadiPac

backward-curved, single-intake
with support bracket



Nominal data

Item	8300100104	
Motor	E11233-60	
Phase		3~
Nominal voltage	VAC	400
Nominal voltage range	VAC	380 .. 480
Frequency	Hz	50/60
Method of obtaining data		ml
Speed (rpm)	min ⁻¹	4560
Power consumption	W	2750
Current draw	A	4.3
Min. ambient temperature	°C	-40
Max. ambient temperature	°C	40

ml = Max. load · me = Max. efficiency · fa = Free air · cs = Customer specification · ce = Customer equipment
Subject to change

Data according to Commission Regulation (EU) 327/2011 (prEN 17166)

		Actual	Req. 2015			
01 Overall efficiency η_{es}	%	70.9	56.1	09 Power consumption P_{ed}	kW	2.75
02 Measurement category		A		09 Air flow q_v	m ³ /h	4370
03 Efficiency category		Static		09 Pressure increase p_{fs}	Pa	1533
04 Efficiency grade N		76.8	62	10 Speed (rpm) n	min ⁻¹	4560
05 Variable speed drive		Yes		11 Specific ratio*		1.02

Data obtained at optimum efficiency level.

* Specific ratio = $1 + p_g / 100\,000\text{ Pa}$

LU-215838

The efficiency values displayed for achieving conformity with the Ecodesign Regulation EU 327/2011 has been reached with defined air duct components (e.g. inlet rings).
The dimensions must be requested from ebm-papst. If other air conduction geometries are used on the installation side, the ebm-papst evaluation loses its validity/the conformity must be confirmed again.
The product does not fall within the scope of Regulation (EU) 2019/1781 due to the exception specified in Article 2 (2a) (motors completely integrated into a product).



8300100104
VBH0310CTRLS

EC centrifugal module - RadiPac

backward-curved, single-intake
with support bracket



Technical description

Weight	20.7 kg
Size	310 mm
Motor size	112
Rotor surface	Painted black
Electronics housing material	Die-cast aluminum
Impeller material	PP plastic
Support plate material	Sheet steel, galvanized
Support bracket material	Steel, painted black
Inlet nozzle material	ABS plastic
Number of blades	5
Direction of rotation	Clockwise, viewed toward rotor
Degree of protection	IP55
Insulation class	"F"
Moisture (F) / Environmental (H) protection class	H1
Ambient temperature note	Occasional start-up at temperatures between -40°C and -25°C is permitted. For continuous operation at ambient temperatures below -25°C (such as refrigeration applications), use must be made of a fan design with special low-temperature bearings.
Max. permitted ambient temp. for motor (transport/storage)	+80 °C
Min. permitted ambient temp. for motor (transport/storage)	-40 °C
Installation position	See legend on product drawing
Condensation drainage holes	On rotor side
Mode	S1
Motor bearing	Ball bearing
Technical features	<ul style="list-style-type: none"> - Operation and alarm display with LED - External 15-50 VDC input (parameterization) - Alarm relay - Integrated PI controller - Configurable inputs/outputs (I/O) - MODBUS V6.3 - Motor current limitation - RS-485 MODBUS-RTU - Soft start - Voltage output 3.3-24 VDC, Pmax = 800 mW - Control interface with SELV potential safely disconnected from the mains - Thermal overload protection for electronics/motor - Line undervoltage / phase failure detection - Vibration sensor
EMC immunity to interference	According to EN 61000-6-2 (industrial environment)
EMC interference emission	According to EN 61000-6-3 (household environment), except EN 61000-3-2 for professionally used equipment with a total rated power greater than 1 kW
Touch current according to IEC 60990 (measuring circuit Fig. 4, TN system)	<= 3.5 mA
Electrical hookup	Terminal box
Motor protection	Electronic motor protection



8300100104
VBH0310CTRLS

EC centrifugal module - RadiPac

backward-curved, single-intake
with support bracket



Protection class assignment	I; If a protective earth is connected by the customer This component for installation may have several local protection classes. This information relates to this component's basic design. The final protection class is based on the component's intended installation and connection.
Conformity with standards	EN 61800-5-1; CE; UKCA
Approval	UL 1004-7 + 60730-1; EAC; CSA C22.2 No. 77 + CAN/CSA-E60730-1



8300100104
VBH0310CTRLS

EC centrifugal module - RadiPac

backward-curved, single-intake
with support bracket



Product drawing

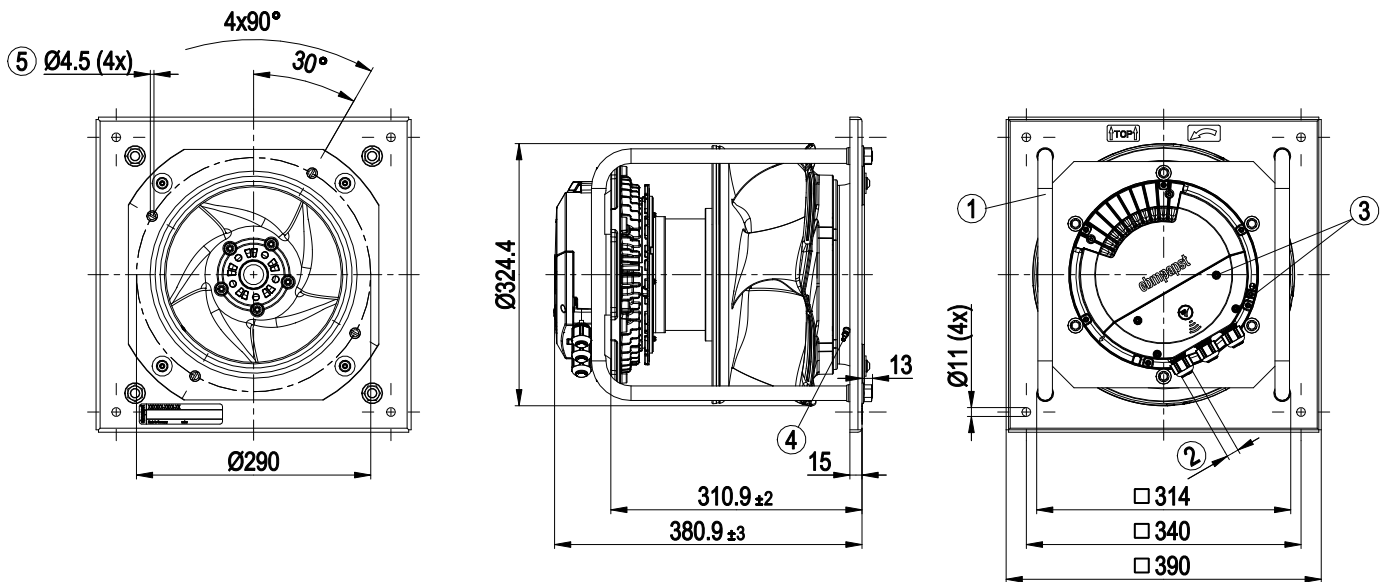

1	Installed position: shaft horizontal (install support struts only vertically as illustrated) or rotor on bottom; rotor on top on request
2	Cable diameter min. 4 mm, max. 10 mm, tightening torque 4 ± 0.6 Nm (The tightening torque is designed for PVC cables. If the cable materials are different, the tightening torque may have to be adjusted)
3	Tightening torque 1.5 ± 0.2 Nm
4	Inlet ring with pressure tap (k-factor: 115)
5	Fastening holes for FlowGrid 25310-2-2957 (not included in scope of delivery) are provided and must be subsequently opened as required



Connection diagram

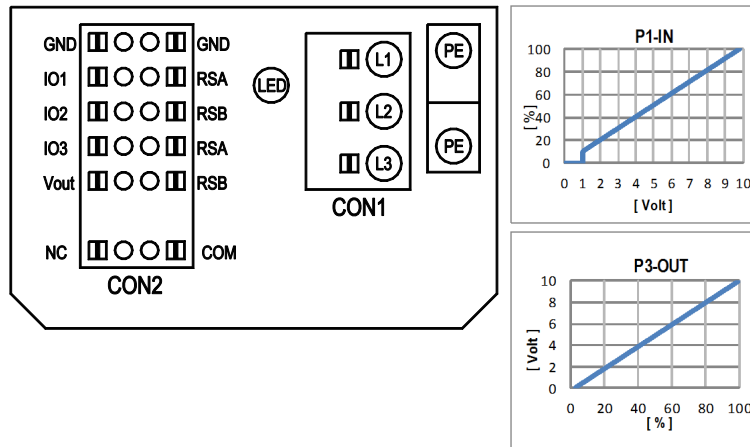

No.	Conn.	Designation	Function/assignment
	CON1	L1, L2, L3	Power supply, phase, see nameplate for voltage range
	PE	PE	Protective earth
	CON2	RSA	RS485 interface for MODBUS, RSA; SELV
	CON2	RSB	RS485 interface for MODBUS, RSB; SELV
	CON2	GND	Reference ground for control interface, SELV
	CON2	IO1	Function parameterizable (see "Optional interface functions" table) Factory setting: Digital input - high active, function: Disable input, SELV - inactive: Pin open or applied voltage < 1.5 VDC - active: applied voltage 3.5-50 VDC Reset function: Triggering of error reset on change of state from "enabled" to "disabled"
	CON2	IO2	Function parameterizable (see "Optional interface functions" table) Factory setting: Analog input 0-10 V/PWM, Ri=100 kΩ, function: Set value Characteristic curve parameterizable (see input characteristic curve P1-IN), SELV
	CON2	IO3	Function parameterizable (see "Optional interface functions" table) Factory setting: Analog output 0-10 V, max. 5 mA, function: Actual speed Characteristic curve parametrizable (see output characteristic curve P3-OUT), SELV
	CON2	Vout	Voltage output 3.3-24 VDC ±5%, Pmax=800 mW, voltage parameterizable Factory setting: 10 VDC short-circuit-proof, supply for external devices, SELV alternatively: 15-50 VDC input for parameterization via MODBUS without line voltage
	CON2	COM	Status relay, floating status contact, common connection, contact rating 250 VAC / 2 A (AC1) / min. 10 mA, reinforced insulation on supply side and on control interface side
	CON2	NC	Status relay, floating status contact, break for failure
		LED	green: status = good, ready for operation orange: status = warning red: status = failure
		P1-IN	Input characteristic curve
		P3-OUT	Output characteristic curve

Terminal/plug assignment

CON2	configurable IO mode	electrical specification	configurable IO functions: normal / inverse	
			MODBUS Register for IO mode configuration	source: set value
IO1	o Din1 (active high), digital input	active: applied voltage 3.5-50VDC, SELV not active: pin open or applied voltage < 1.5VDC	D158 [0]	source: set value
	o Ain1 0-10V/PWM: analog input	RI = 100k, characteristic curve parameterizable, $f_{PWM} = 1k..10kHz$, SELV	D158 [2]	switch: sensor value
	o Tach out (open collector output)	Umax = 50VDC, I _{max} = 20mA, SELV	D158 [5]	switch: parameter set: #1 / #2
	o Diagnostics out (open collector output)	Umax = 50VDC, I _{max} = 20mA, SELV	D158 [6]	switch: control function: heating (pos.) cooling (neg.)
IO2	o Din2 (active high), digital input	active: applied voltage 3.5-50VDC, SELV not active: pin open or applied voltage < 1.5VDC	D159 [0]	switch: direction of rotation: cw / ccw
	o Ain2 0-10V/PWM: analog input	RI = 100k, characteristic curve parameterizable, $f_{PWM} = 1k..10kHz$, SELV	D159 [2]	switch: set value source
	o Ain2 4-20mA: analog input	RI = 125R, characteristic curve parameterizable, SELV	D159 [3]	switch: fan enable / disable
	o Din3 (active high), digital input	active: applied voltage 3.5-50VDC, SELV not active: pin open or applied voltage < 1.5VDC	D15A [0]	signal: tach out
IO3	o Din3 (active low), digital input	active: applied voltage < 1.5VDC, SELV not active: pin open or applied voltage 3.5-50VDC	D15A [1]	signal: diagnostics out (selected directly via IO mode)
	o PWMIn3: digital input, idle level high	PWM = 40Hz - 10kHz, characteristics parameterizable	D15A [7]	signal: fan modulation level %
	o PWMIn3: digital input, idle level low	active: pin open or applied voltage 3.5-50VDC not active: applied voltage < 1.5VDC, SELV	D15A [8]	signal: actual speed
	o Aout3 0-10V: analog output	active: applied voltage 3.5-50VDC not active: pin open or applied voltage < 1.5VDC, SELV	D15A [4]	signal: remote control output 0-10V
Vout	o Tacho out (pulses), analog output	function parameterizable, max. 5mA max output frequency 300Hz SELV	D15A [5]	pulse input for auto-addressing
	o Diagnostics out (pulses)	0-10V/max. 5mA max output frequency 300Hz SELV	D15A [6]	pulse output for auto-addressing
	o Diagnostics out (pulses)	0-10V/max. 5mA max output frequency 300Hz SELV	D15A [6]	
RSA	RS485 bus connection,	MODBUS RTU, specification V6.3, SELV		
RSB	voltage output	voltage parameterizable 3.3...24VDC +/- 5%, P _{max} =800mW, short-circuit-proof, supply for external devices, SELV	D16E [..]	

o configurable option

For further information and additional functions see EC Control Software, Fan-Set-App,
or MODBUS Parameter Specification V6.3



Curves: Air performance 50 Hz

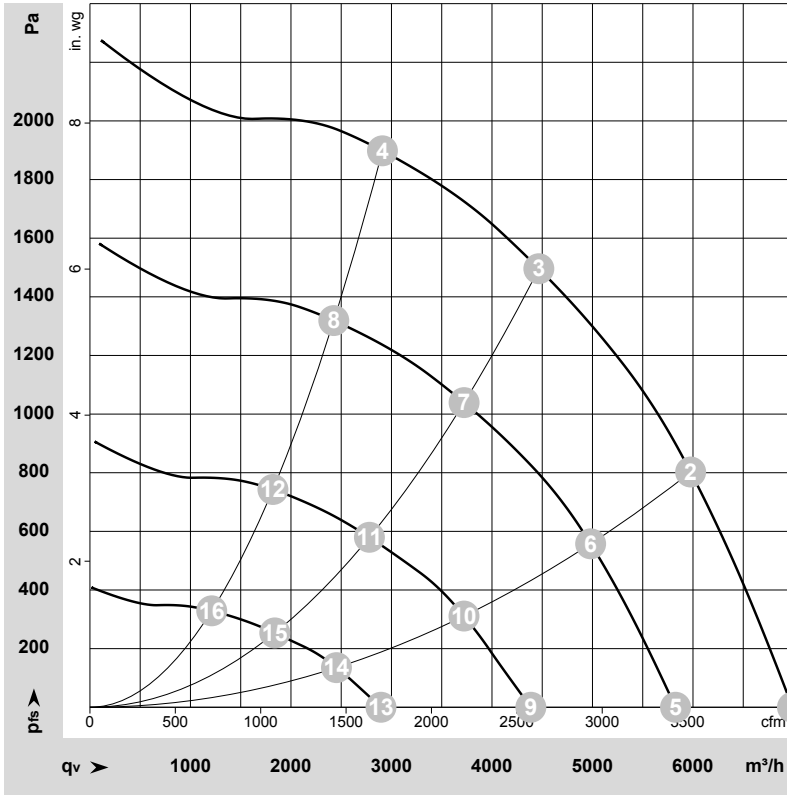

$\rho = 1.15 \text{ kg/m}^3 \pm 2 \%$

Measurement: LU-215838-1

Air performance measured according to ISO 5801 installation category A. For detailed information on the measurement setup, contact ebmpapst. Intake sound level: Sound power level according to ISO 13347 / sound pressure level measured at 1 m distance from fan axis. The values given are valid under the specified measuring conditions and may vary due to conditions of installation. For deviations from the standard configuration, the parameters have to be checked on the installed unit.

Measured values

	Wired	U	f	n	P _e	I	LpA _{in}	LwA _{in}	LwA _{out}	LwA	q _v	P _{fs}	q _v	P _{fs}
		V	Hz	min ⁻¹	W	A	dB(A)	dB(A)	dB(A)	dB	m ³ /h	Pa	cfm	in. wg
1	3~	400	50	4560	1855	2.94	89	97	100	102	6990	0	4115	0.00
2	3~	400	50	4560	2549	3.96	82	90	94	96	5975	800	3520	3.21
3	3~	400	50	4560	2750	4.30	77	84	92	93	4465	1500	2630	6.02
4	3~	400	50	4560	2618	4.06	80	89	94	95	2910	1900	1715	7.63
5	3~	400	50	3800	1121	1.87	84	92	95	97	5825	0	3430	0.00
6	3~	400	50	3800	1512	2.43	77	85	90	91	4980	559	2930	2.24
7	3~	400	50	3800	1628	2.59	72	79	87	88	3725	1041	2190	4.18
8	3~	400	50	3800	1546	2.47	75	84	90	91	2425	1322	1430	5.31
9	3~	400	50	2850	526	1.07	77	85	88	90	4385	0	2580	0.00
10	3~	400	50	2850	689	1.28	69	78	82	84	3720	312	2190	1.25
11	3~	400	50	2850	735	1.34	65	72	80	81	2780	580	1635	2.33
12	3~	400	50	2850	712	1.31	68	75	81	82	1820	745	1070	2.99
13	3~	400	50	1900	198	0.56	67	75	78	80	2895	0	1705	0.00
14	3~	400	50	1900	245	0.65	61	68	73	74	2455	136	1445	0.55
15	3~	400	50	1895	259	0.67	56	63	70	70	1840	254	1080	1.02
16	3~	400	50	1895	251	0.66	58	64	70	71	1210	330	715	1.32

Wired = Wiring · U = Voltage · f = Frequency · n = Speed (rpm) · P_e = Power consumption · I = Current draw · LpA_{in} = Sound pressure level intake side · LwA_{in} = Sound power level intake side
LwA_{out} = Sound power level outlet side · q_v = Air flow · P_{fs} = Pressure increase