

Centrifugal fan model TR, Es.4

Single inlet fan, direct driven with an IEC-standard motor in form B3 which is mounted on a motorbase. The overhang impeller is mounted on the motor shaft and has backwardly curved blades. The blades are welded between the back plate disc and the aerodynamically formed front plate. The robust industrial fan is totally made of steel and painted in the agate grey color RAL 7037. The fan is suitable for the transportation of clean and slightly dusty air.

General data:

Drive	direct
Motor position	horizontal
Material casing/base	Steel
Material impeller/hub	Steel
Motorcoating/protection	RAL 7037
Operating temperature (max.)	15 (80) °C
Medium density (altitude 0 m)	1,226 kg/m ³
Impeller speed	2950 rpm
Weight	326 kg
Sound pressure level ±3	81 dB(A)

(at 1,5 m near the fan with inlet and outlet ducted, in free field)

Electric motor:

	180M	IEC
Power	22	kW
Motor speed	2.950	rpm
Electric supply	3x400V50Hz	V/Hz
Full load current	39,7	A
Enclosure	55	IP
Shape	B3T	
Efficiency class	IE3	

Curve TR 632 @ 2950rpm @ 15°C @ 0m

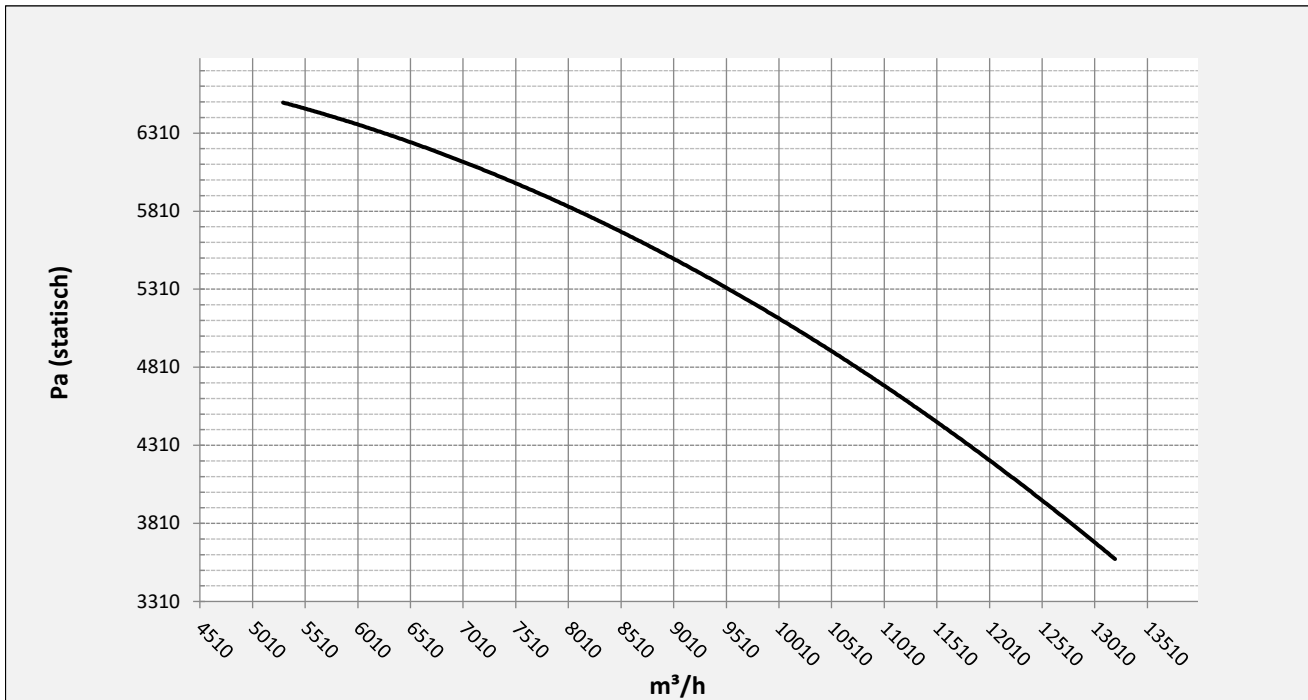

Possible discharge positions:



* (Pos 180 and 225 extra price)

Possible accessories

Mounting profiles for load distribution	--
Counterflange inlet/outlet	zz Ø400 / pz 400x280
Flexible connection inlet/outlet max. 80°C	zz Ø450 / pz Ø500
Anti-vibration mountings	6x 40x30/B/70° ShA
Inspectiondoor	
Drain connection	
Shaft seal without asbestos	
Coolingwheel (medium max. 150°C)	(incl. coating RAL9006)
Flexible connection inlet/outlet max. 150°C	zz Ø450 / pz Ø500
ATEX version	Zone 1 / 2 / 21 / 22
ATEX motor	Ex nA / Exe / Ex de
Coating suitable for outdoor application	RAL 5010 / RAL
Stainless steel version	304 / 316 / ...
Acoustic enclosure	

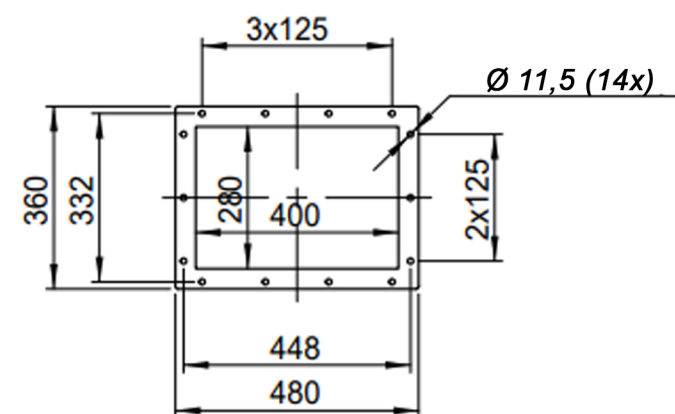
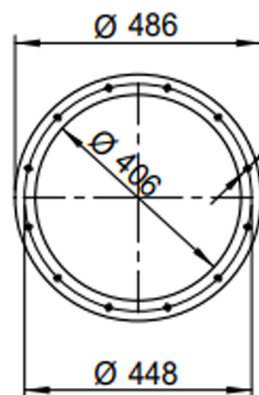
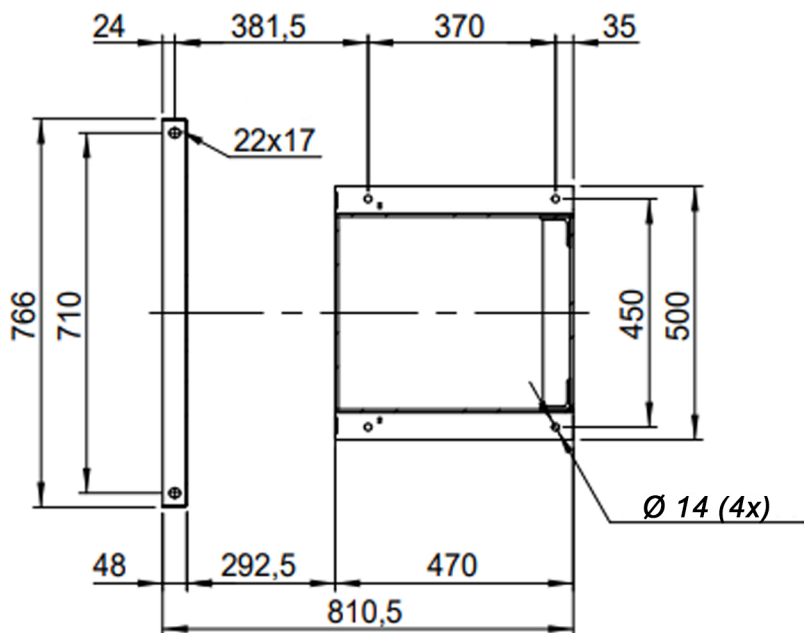
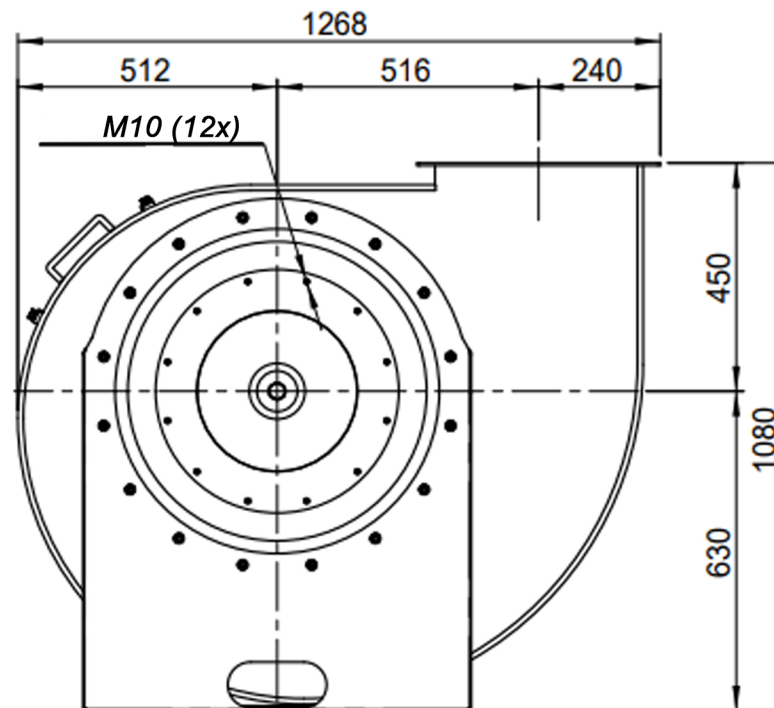
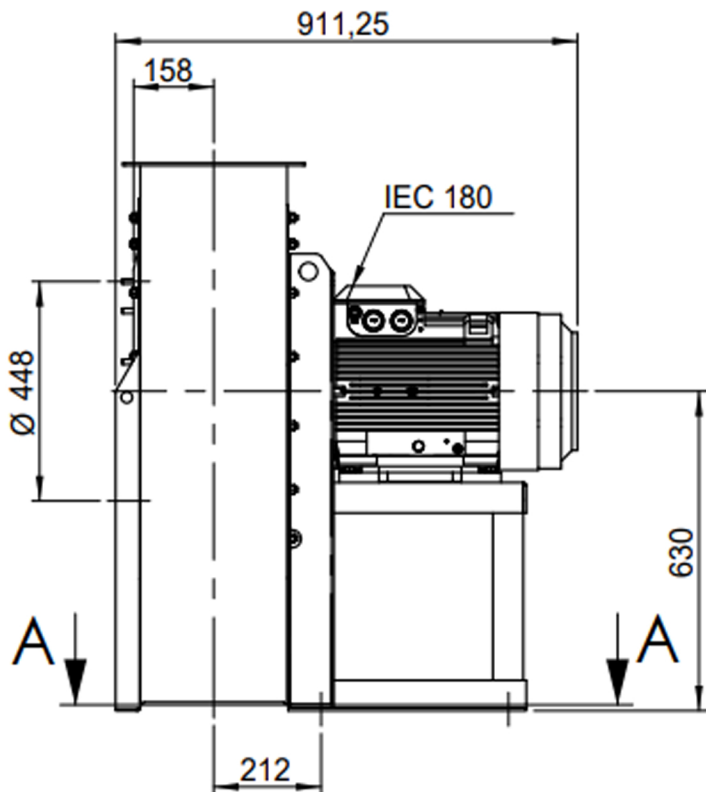

DESCRIPTION-BESCHRIJVING	SCHAAL	GEMAAKT - PREPARED	FORMAAT
TR632 - RD0	1:15	Overmeer E.	A4
	DATUM		
	2/11/2023		
N.TEKENING - N.DRAWING			REV.
			V1TR 632
			00