

TH 561B

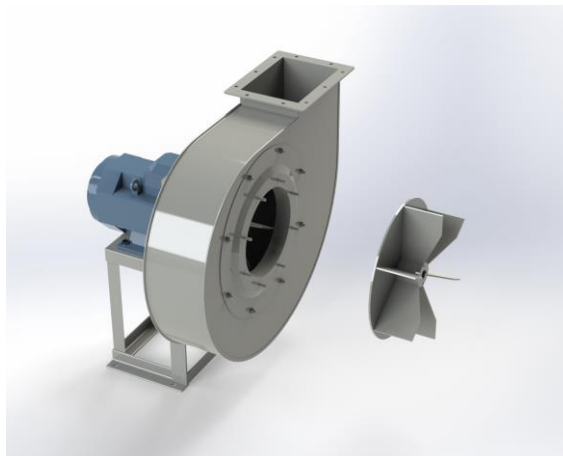

Centrifugal fan model TH Es.4

Single inlet fan, direct driven with an IEC-standard motor in form B3 which is mounted on a motorbase. The overhang impeller is mounted on the motor shaft and has an open blade impeller. The robust industrial fan is totally made of steel and painted in the agate grey color RAL 7037. The fan is suitable for the transport of granules and trimmings in nylon; for loading solid fuels into boilers, etc.

General data:

Drive	direct
Motor position	horizontal
Material casing/base	Steel
Material impeller/hub	Steel
Motorcoating/protection	RAL 7037
Operating temperature (max.)	15 (80) °C
Medium density (altitude 0 m)	1,226 kg/m ³
Impeller speed	2960 rpm
Weight	394 kg
Sound pressure level ±3	90 dB(A)

(at 1,5 m near the fan with inlet and outlet ducted, in free field)

Electric motor:

	200L	IEC
Power	30	kW
Motor speed	2.960	rpm
Electric supply	3x400V50Hz	V/Hz
Full load current	54,5	A
Enclosure	55	IP
Shape	B3T	
Efficiency class	IE3	

Curve TH 561B @ 2960rpm @ 15°C @ 0m

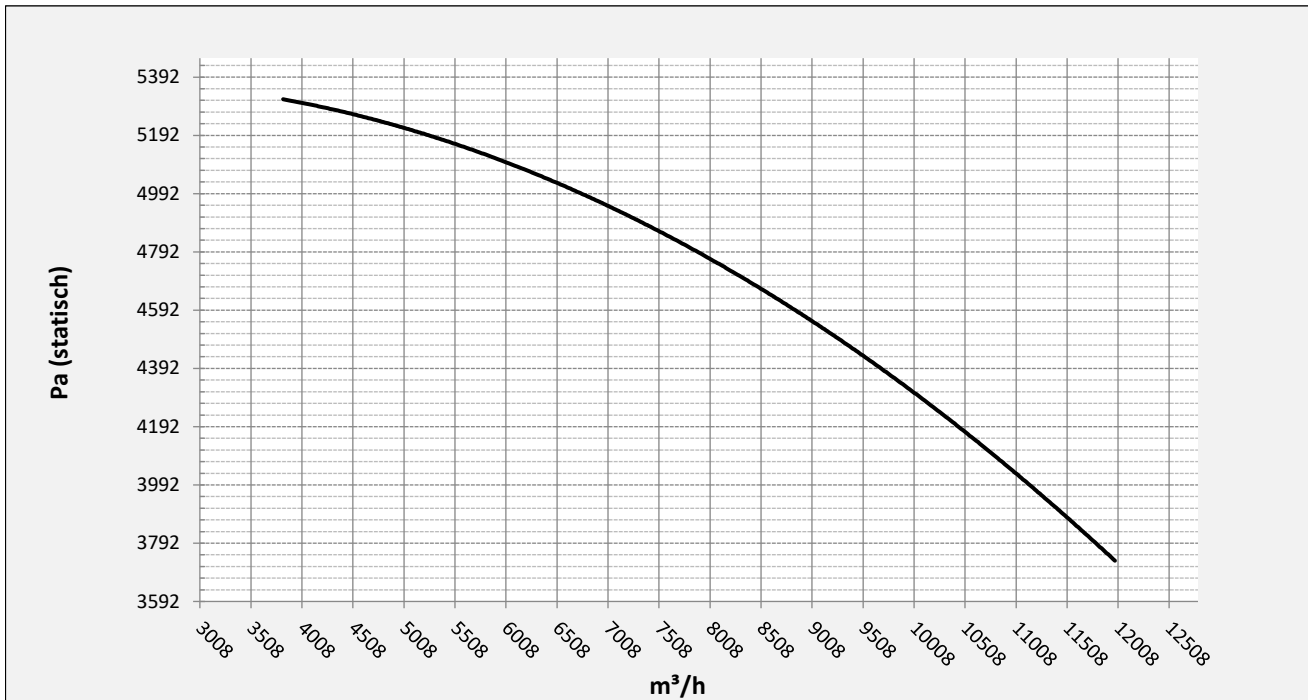

Possible discharge positions:

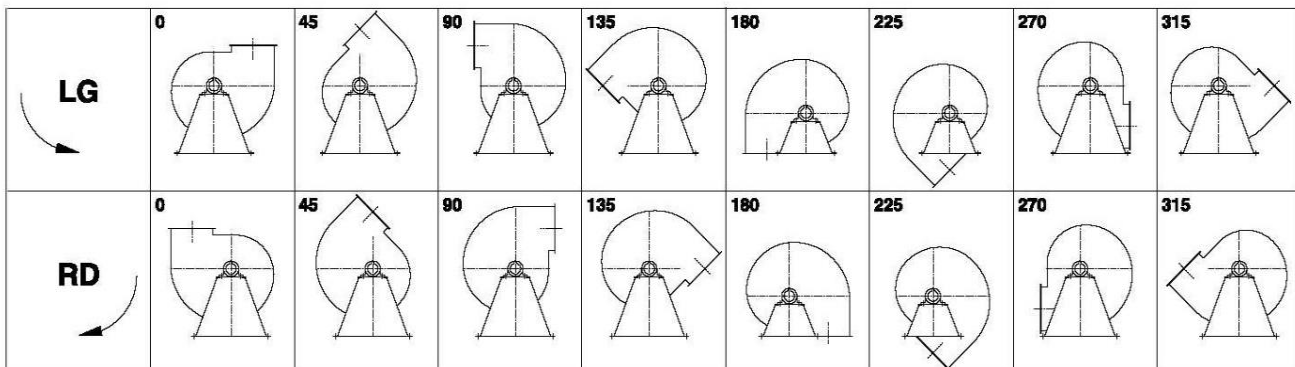

* (Pos 180 and 225 extra price)

Possible accessories

Mounting profiles for load distribution	AP20001ST
Counterflange inlet/outlet	zz Ø355 / pz 355x250
Flexible connection inlet/outlet max. 80°C	zz Ø400 / pz Ø450
Anti-vibration mountings	4x 70x45/B/70° ShA
Inspectiondoor	
Drain connection	
Shaft seal without asbestos	
Coolingwheel (medium max. 150°C)	(incl. coating RAL9006)
Flexible connection inlet/outlet max. 150°C	zz Ø400 / pz Ø450
ATEX version	Zone 1 / 2 / 21 / 22
ATEX motor	Ex nA / Exe / Ex de
Coating suitable for outdoor application	RAL 5010 / RAL
Stainless steel version	304 / 316 / ...
Acoustic enclosure	

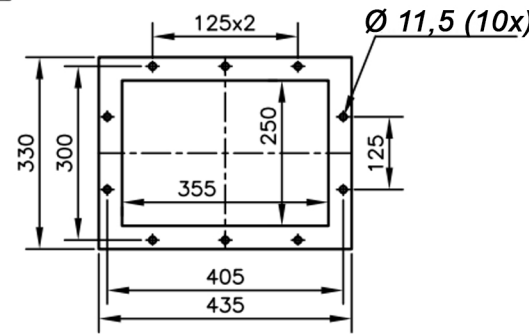
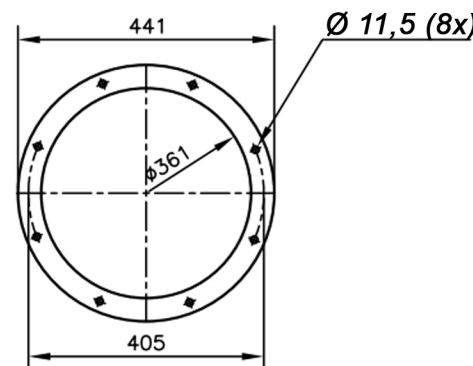
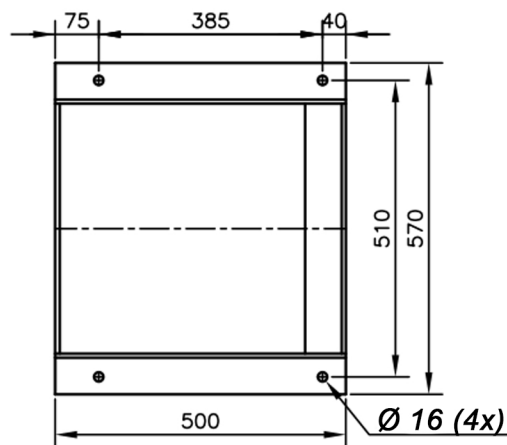
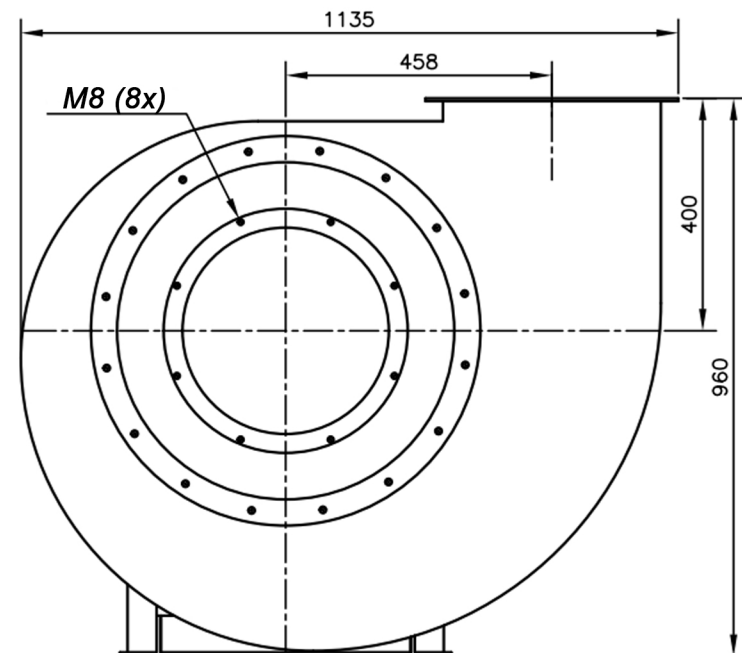
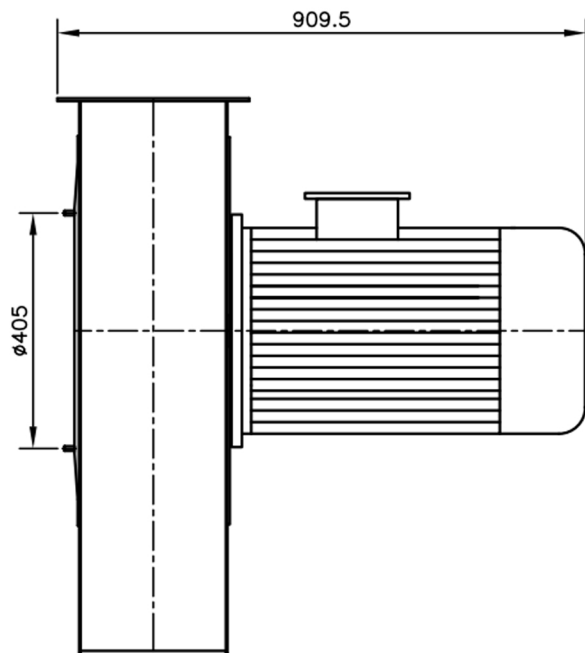
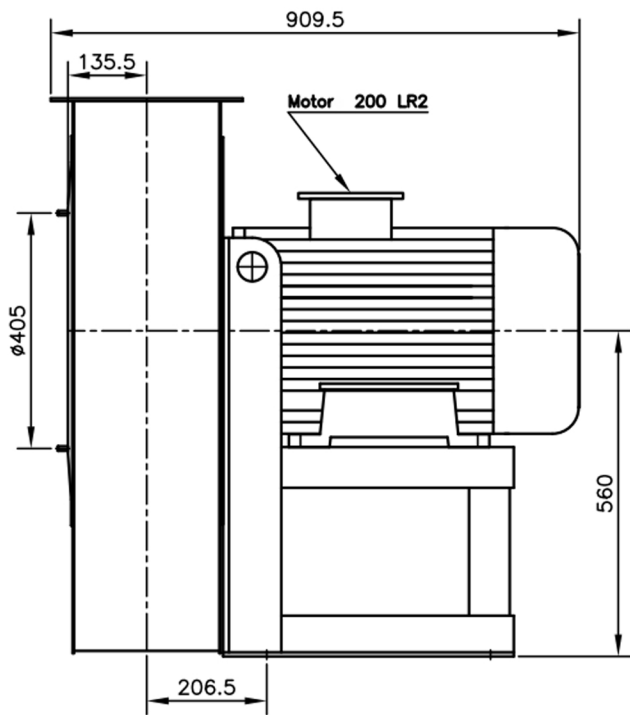

DESCRIPTION-BESCHRIJVING	SCHAAL	GEMAAKT - PREPARED	FORMAAT
TH561/B - RD0	1:13	Overmeer E.	A4
	DATUM		
	01/12/2023		
N.TEKENING - N.DRAWING			REV.
			00
V1TH561/B			

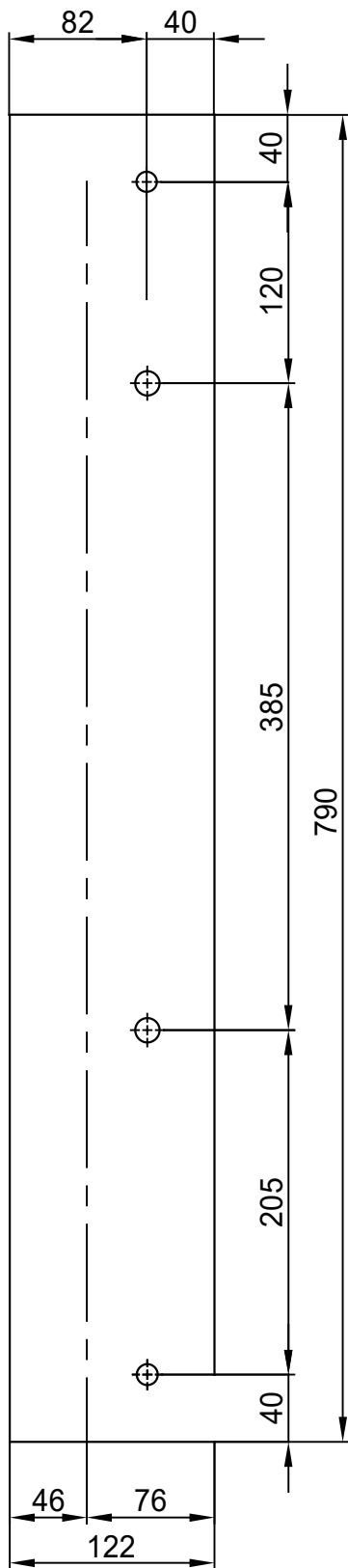

Sp. 40/10

N°2 ForoØ14.5

n°1 PIEGA DX
n°1 PIEGA SX

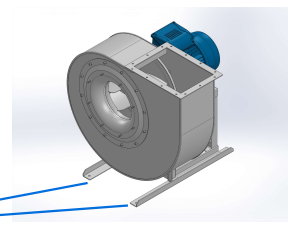

COMM.
N°

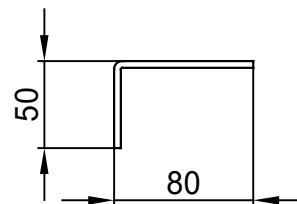

N°2 ForiØ12.5

00	04/02/2016	PRIMA EMISSIONE	RK	RK
REV	DATA - DATE	DESCRIZIONE - DESCRIPTION	DISEGNATO PREPARED	APPROVATO APPROVED
DESCRIZIONE - DESCRIPTION		MATERIALE - MATERIAL	NR.FILE	PESO - WEIGHT
		Fe 360		Kg
DESCRIZIONE - DESCRIPTION		SCALA 1:4.5	DISEGNATO - PREPARED	FORMATO
Staffe per Puffer L=750		DATA 04/02/2016	RK	A4
IEC 200 / AP series		SOSTITUISCE IL - REPLACED THE N°		
		SOSTITUITO DAL - REPLACES BY N°		
N.DISEGNO - N.DRAWING			REV.	
STF-AP20001ST			01	