

TH 1121B

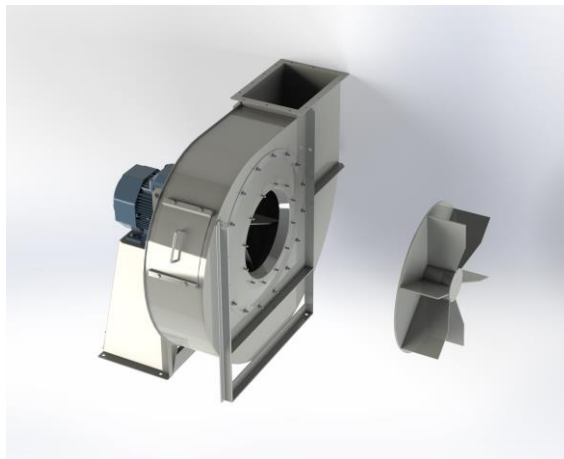

Centrifugal fan model TH Es.4

Single inlet fan, direct driven with an IEC-standard motor in form B3 which is mounted on a motorbase. The overhang impeller is mounted on the motor shaft and has an open blade impeller. The robust industrial fan is totally made of steel and painted in the agate grey color RAL 7037. The fan is suitable for the transport of granules and trimmings in nylon; for loading solid fuels into boilers, etc.

General data:

Drive	direct
Motor position	horizontal
Material casing/base	Steel
Material impeller/hub	Steel
Motorcoating/protection	RAL 7037
Operating temperature (max.)	15 (80) °C
Medium density (altitude 0 m)	1,226 kg/m ³
Impeller speed	1485 rpm
Weight	1.397 kg
Sound pressure level ±3	91 dB(A)

(at 1,5 m near the fan with inlet and outlet ducted, in free field)

Electric motor:

	280M	IEC
Power	90	kW
Motor speed	1.485	rpm
Electric supply	3x400V50Hz	V/Hz
Full load current	158	A
Enclosure	55	IP
Shape	B3T	
Efficiency class	IE4	

Curve TH 1121B @ 1485rpm @ 15°C @ 0m

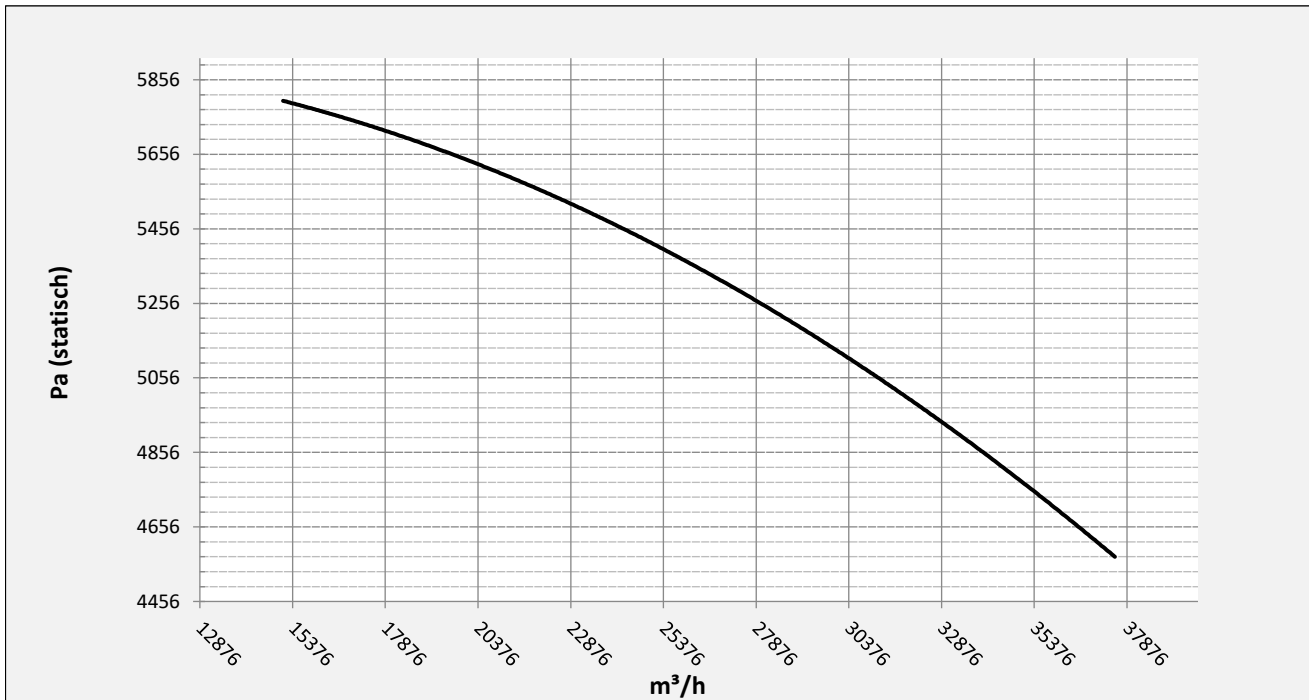

Possible discharge positions:

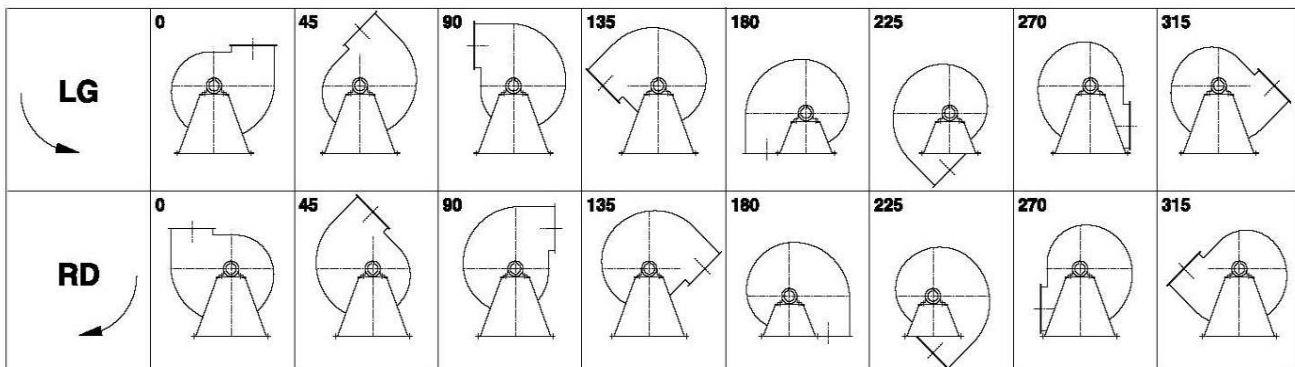

* (Pos 180 and 225 extra price)

Possible accessories

Mounting profiles for load distribution	--
Counterflange inlet/outlet	zz Ø710 / pz 710x500
Flexible connection inlet/outlet max. 80°C	zz Ø800 / pz Ø900
Anti-vibration mountings	6x 100x55/B/55° ShA
Inspection door	
Drain connection	
Shaft seal without asbestos	
Cooling wheel (medium max. 150°C)	(incl. coating RAL9006)
Flexible connection inlet/outlet max. 150°C	zz Ø800 / pz Ø900
ATEX version	Zone 1 / 2 / 21 / 22
ATEX motor	Ex nA / Exe / Ex de
Coating suitable for outdoor application	RAL 5010 / RAL
Stainless steel version	304 / 316 / ...
Acoustic enclosure	

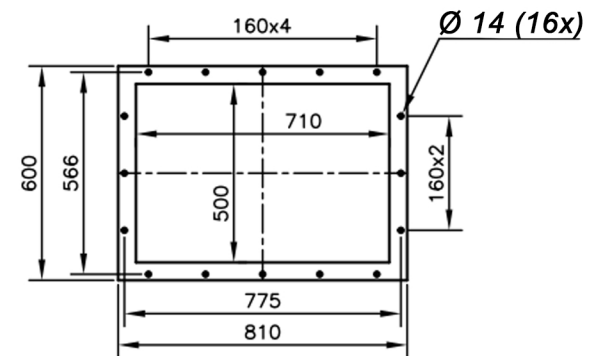
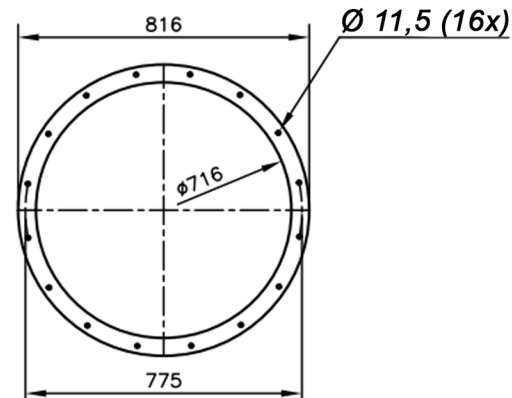
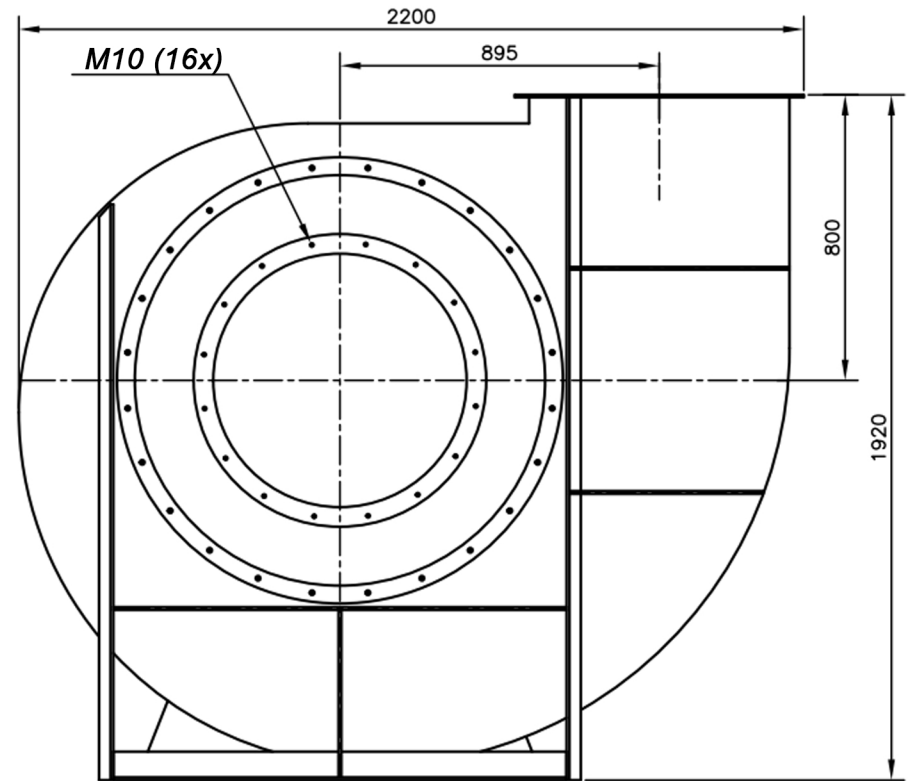
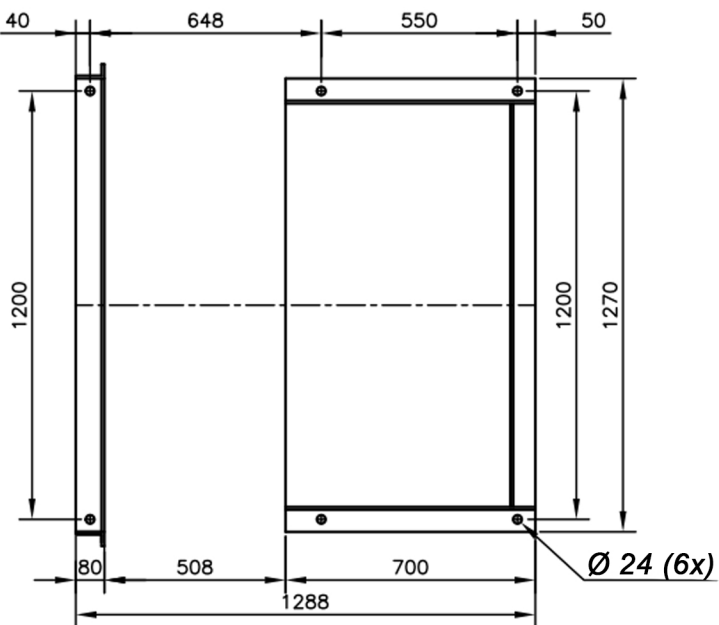
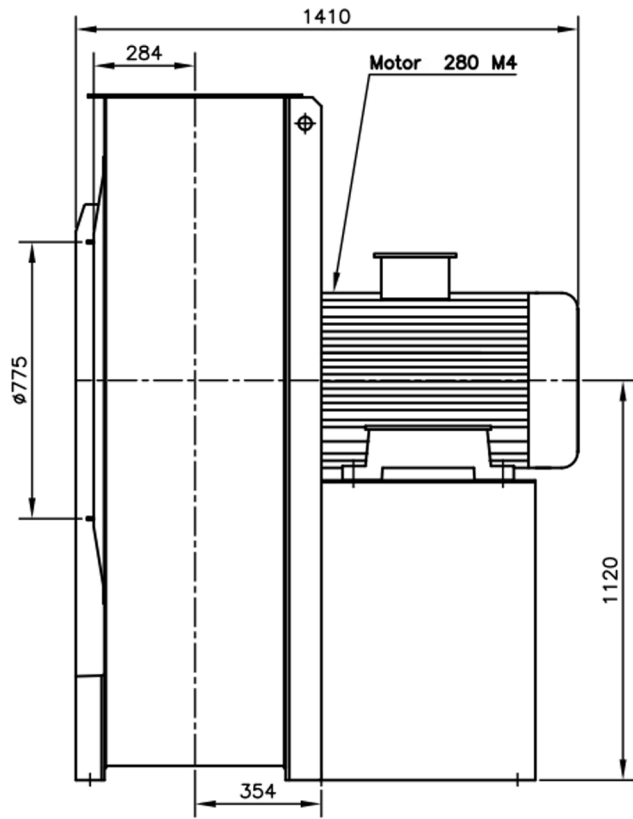

DESCRIPTION-BESCHRIJVING	SCHAAL	GEMAAKT - PREPARED	FORMAAT
	1:21		A4
TH1121/B - RD0	DATUM	Overmeer E.	
	01/12/2023		
N.TEKENING - N.DRAWING			REV.
Slingerland ventilatoren			00
V1TH1121/B			