

## TF 801A

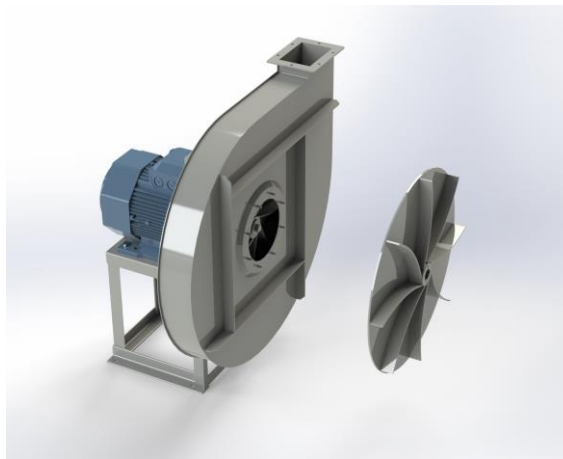

### Centrifugal fan model TF, Es.4

Single inlet fan, direct driven with an IEC-standard motor in form B3 which is mounted on a motorbase. The overhang impeller is mounted on the motor shaft and has backwardly curved blades. The blades are welded between the back plate disc and the aerodynamically formed front plate. The robust industrial fan is totally made of steel and painted in the agate grey color RAL 7037. The fan is suitable for pneumatic transport, sawdust, small wood shavings and granulate.

#### General data:

Drive	direct
Motor position	horizontal
Material casing/base	Steel
Material impeller/hub	Steel
Motorcoating/protection	RAL 7037
Operating temperature (max.)	15 (80) °C
Medium density (altitude 0 m)	1,226 kg/m <sup>3</sup>
Impeller speed	2945 rpm
Weight	276 kg
Sound pressure level ±3	94 dB(A)

*(at 1,5 m near the fan with inlet and outlet ducted, in free field)*

#### Electric motor:

	160M	IEC
Power	15	kW
Motor speed	2.945	rpm
Electric supply	3x400V50Hz	V/Hz
Full load current	27,7	A
Enclosure	55	IP
Shape	B3T	
Efficiency class	IE3	

Curve TF 801A @ 2945rpm @ 15°C @ 0m

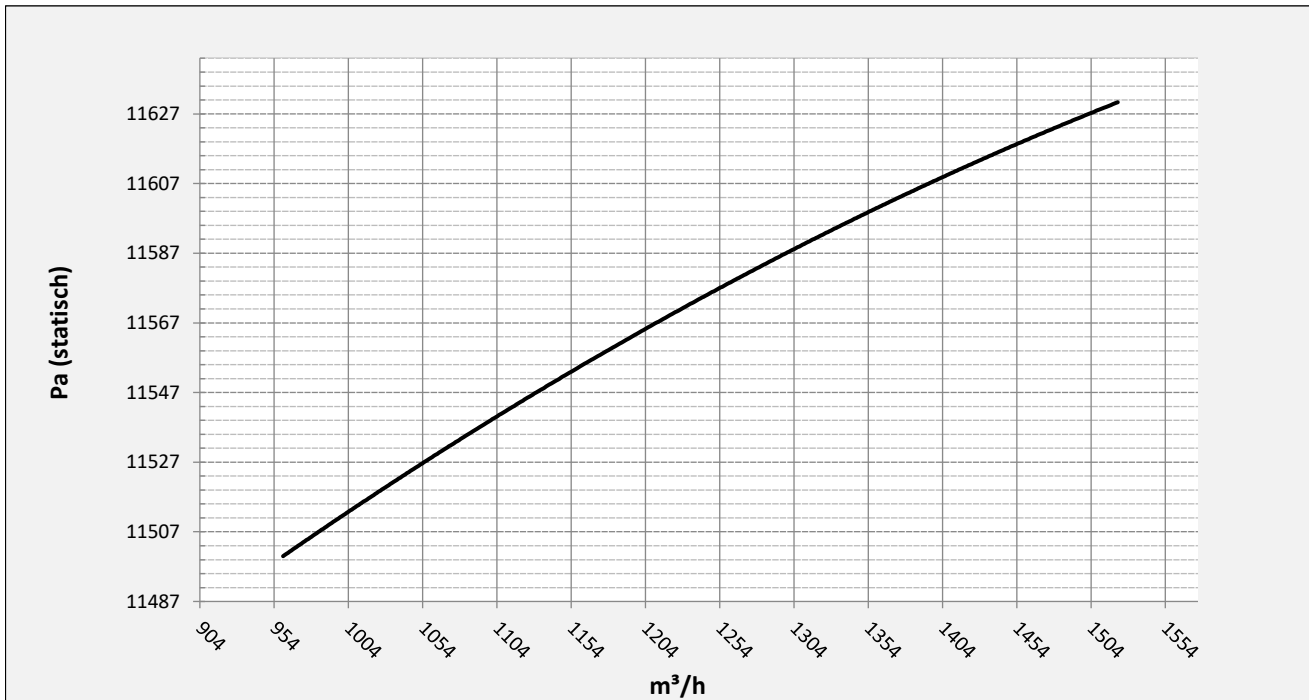

Possible discharge positions:

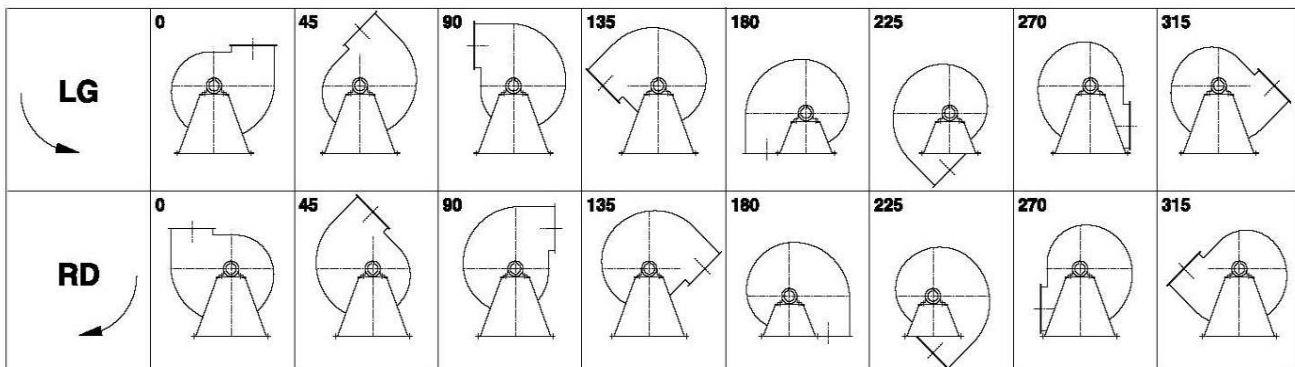

\* (Pos 180 and 225 extra price)

Possible accessories

Mounting profiles for load distribution	AP16001ST
Counterflange inlet/outlet	zz Ø250 / pz 200x140
Flexible connection inlet/outlet max. 80°C	zz Ø250 / pz Ø250
Anti-vibration mountings	4x 50x40/B/40° ShA
Inspection door	
Drain connection	
Shaft seal without asbestos	
Cooling wheel (medium max. 150°C)	( incl. coating RAL9006 )
Flexible connection inlet/outlet max. 150°C	zz Ø250 / pz Ø250
ATEX version	Zone 1 / 2 / 21 / 22
ATEX motor	Ex nA / Exe / Ex de
Coating suitable for outdoor application	RAL 5010 / RAL ....
Stainless steel version	304 / 316 / ...
Acoustic enclosure	

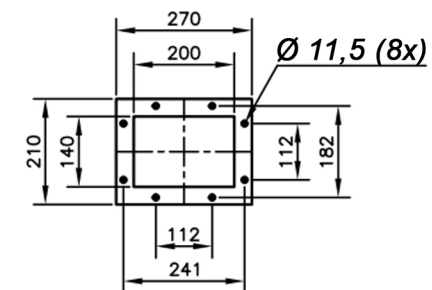
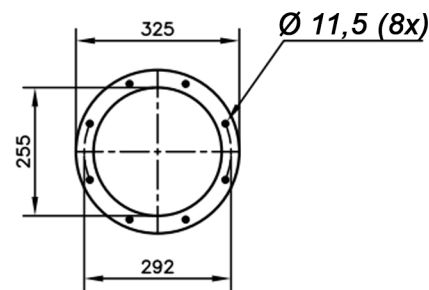
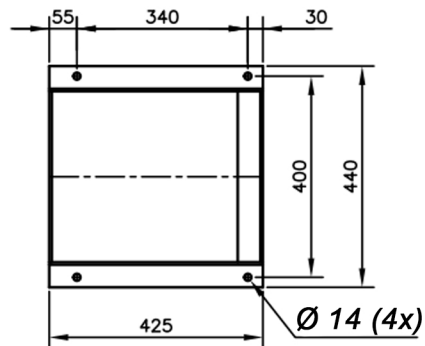
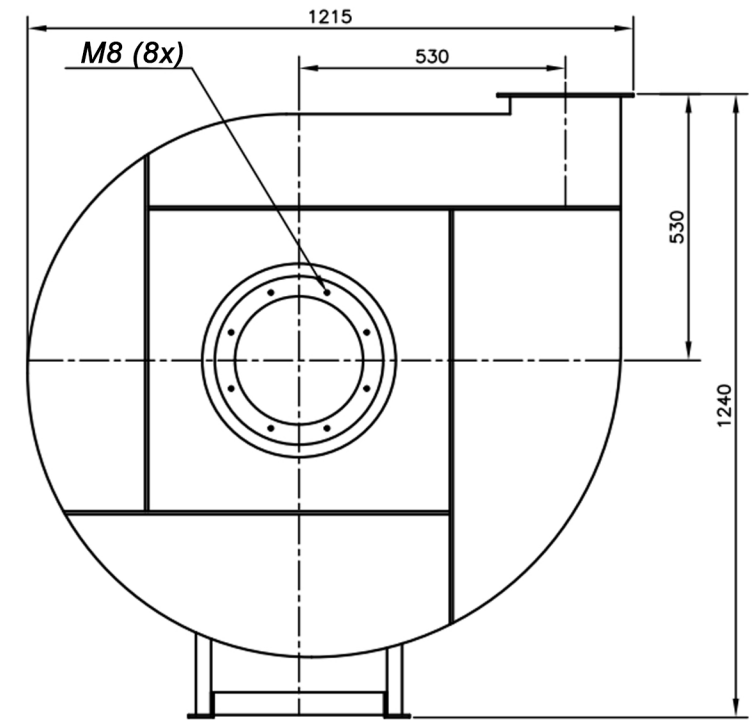
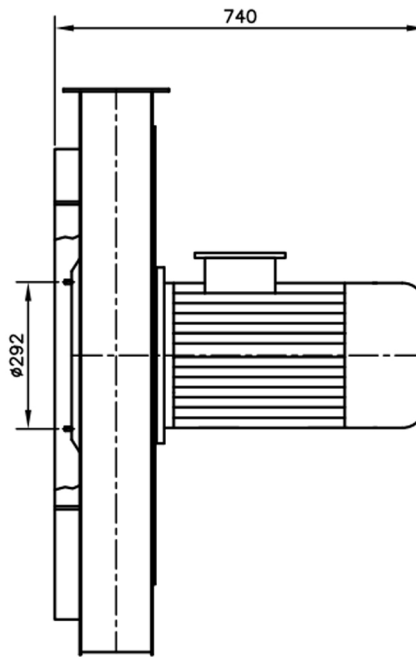
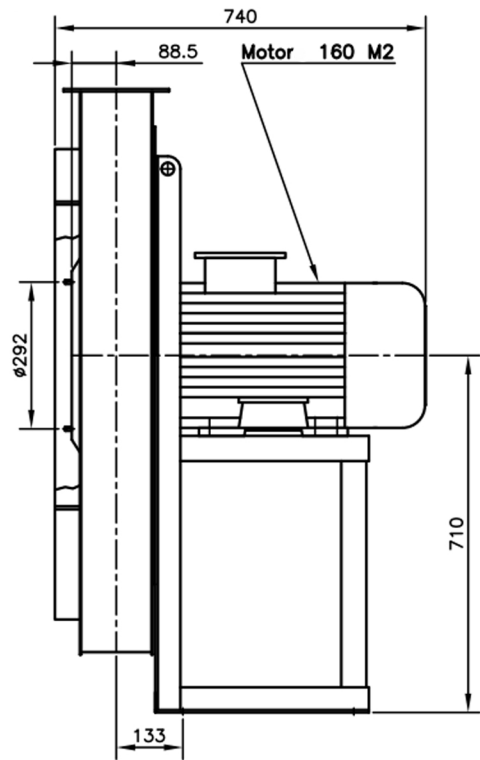

DESCRIPTION-BESCHRIJVING	SCHAAL	GEMAAKT - PREPARED	FORMAAT
	1:15		A4
TF801/A - RD0	DATUM	Overmeer E.	
	29/11/2023		
N.TEKENING - N.DRAWING			REV.
		V1TF801/A	00

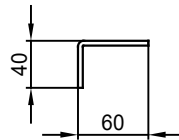
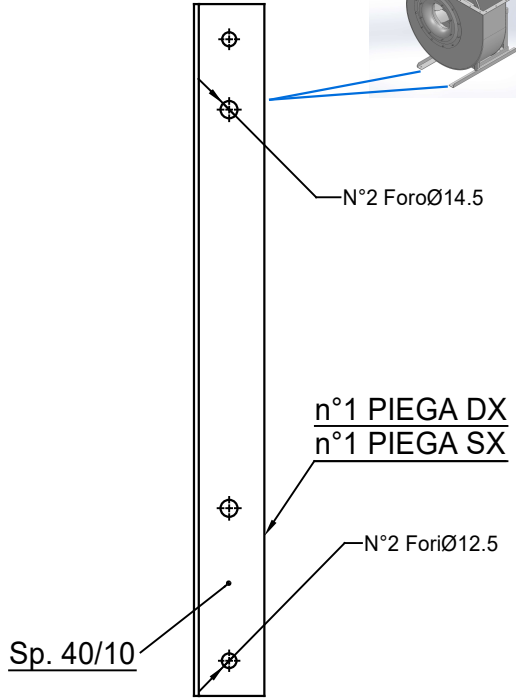
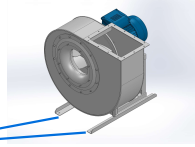
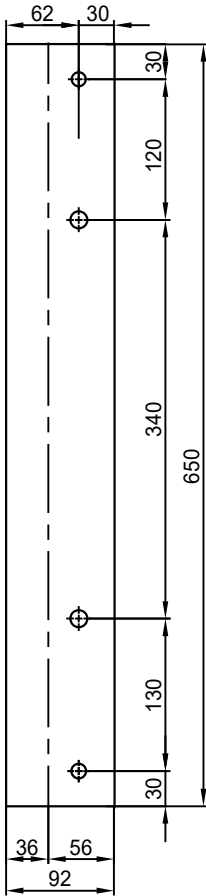

COMM.  
N°

00	04/02/2016	PRIMA EMISSIONE		RK	RK
01	16/09/2020	Extension pedestal		MvS	MvS
REV	DATA - DATE	DESCRIZIONE - DESCRIPTION			APPROVATO APPROVED
DESCRIZIONE - DESCRIPTION		MATERIALE - MATERIAL	NR.FILE	PESO - WEIGHT	
DESCRIZIONE - DESCRIPTION		Fe 360		Kg	
Staffe per Puffer L=650 IEC 160 / AP series			SCALA 1:4.5	DISEGNATO - PREPARED	FORMATO
			DATA 04/02/2016	RK	A4
			SOSTITUISCE IL - REPLACED THE N°		
			SOSTITUITO DAL - REPLACES BY N°		
N.DISEGNO - N.DRAWING				REV.	
STF-AP16001ST					
				01	