

TF 631B

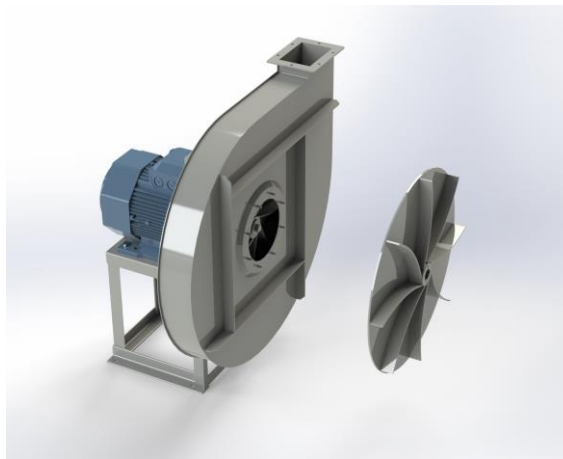

Centrifugal fan model TF, Es.4

Single inlet fan, direct driven with an IEC-standard motor in form B3 which is mounted on a motorbase. The overhang impeller is mounted on the motor shaft and has backwardly curved blades. The blades are welded between the back plate disc and the aerodynamically formed front plate. The robust industrial fan is totally made of steel and painted in the agate grey color RAL 7037. The fan is suitable for pneumatic transport, sawdust, small wood shavings and granulate.

General data:

Drive	direct
Motor position	horizontal
Material casing/base	Steel
Material impeller/hub	Steel
Motorcoating/protection	RAL 7037
Operating temperature (max.)	15 (80) °C
Medium density (altitude 0 m)	1,226 kg/m ³
Impeller speed	2930 rpm
Weight	153 kg
Sound pressure level ±3	89 dB(A)

(at 1,5 m near the fan with inlet and outlet ducted, in free field)

Electric motor:

	132S	IEC
Power	7,5	kW
Motor speed	2.930	rpm
Electric supply	3x400V50Hz	V/Hz
Full load current	14,1	A
Enclosure	55	IP
Shape	B3T	
Efficiency class	IE3	

Curve TF 631B @ 2930rpm @ 15°C @ 0m

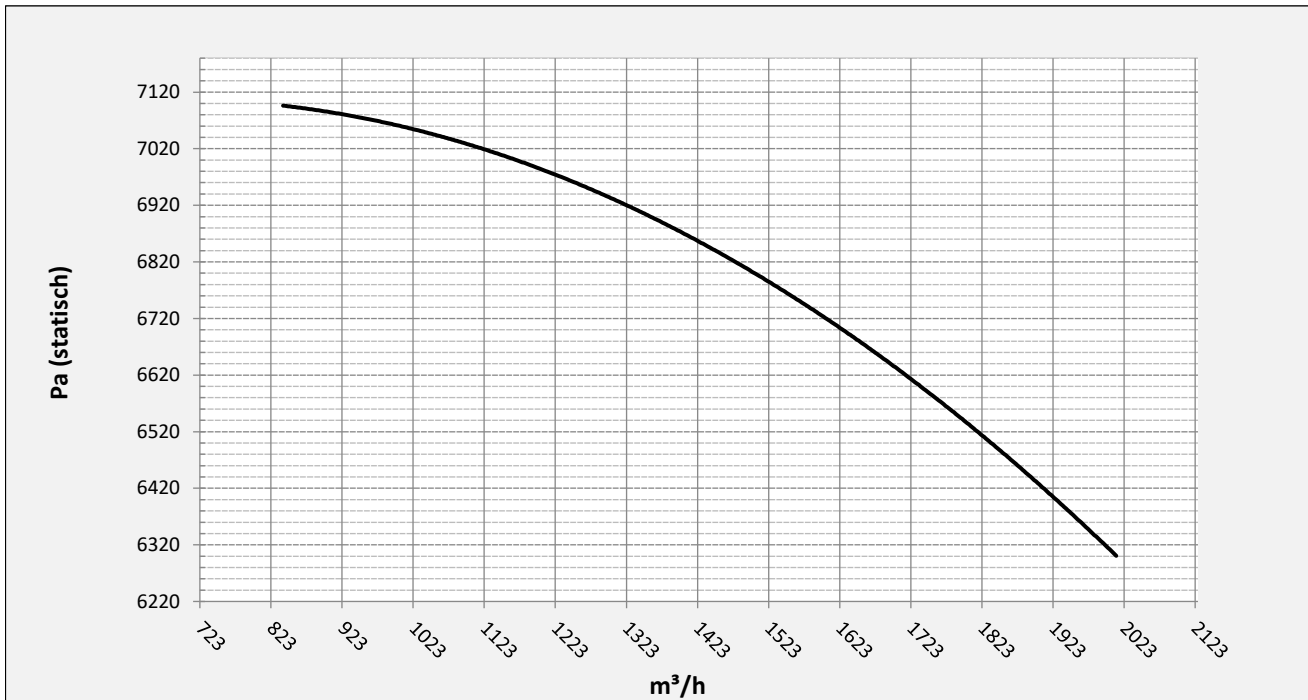

Possible discharge positions:



* (Pos 180 and 225 extra price)

Possible accessories

Mounting profiles for load distribution	AP13201ST
Counterflange inlet/outlet	zz Ø200 / pz 160x112
Flexible connection inlet/outlet max. 80°C	zz Ø250 / pz Ø250
Anti-vibration mountings	4x 40x30/B/40° ShA
Inspection door	
Drain connection	
Shaft seal without asbestos	
Cooling wheel (medium max. 150°C)	(incl. coating RAL9006)
Flexible connection inlet/outlet max. 150°C	zz Ø250 / pz Ø250
ATEX version	Zone 1 / 2 / 21 / 22
ATEX motor	Ex nA / Exe / Ex de
Coating suitable for outdoor application	RAL 5010 / RAL
Stainless steel version	304 / 316 / ...
Acoustic enclosure	

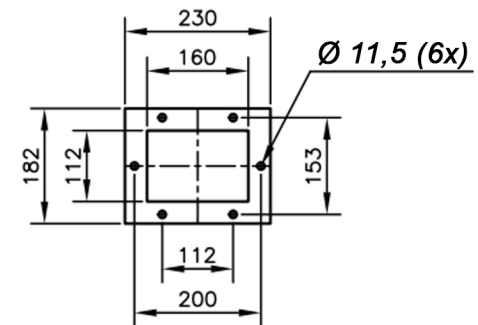
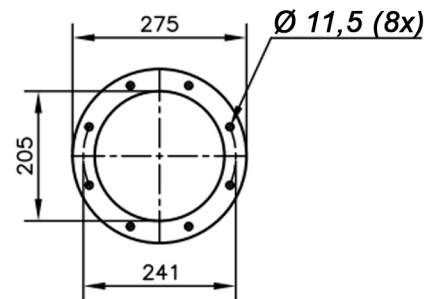
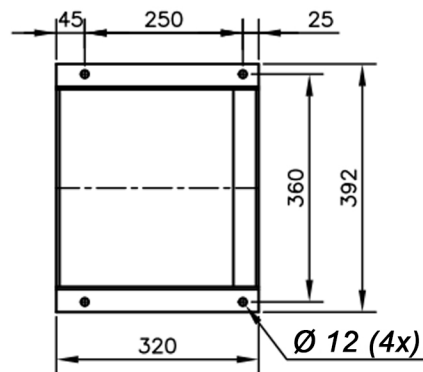
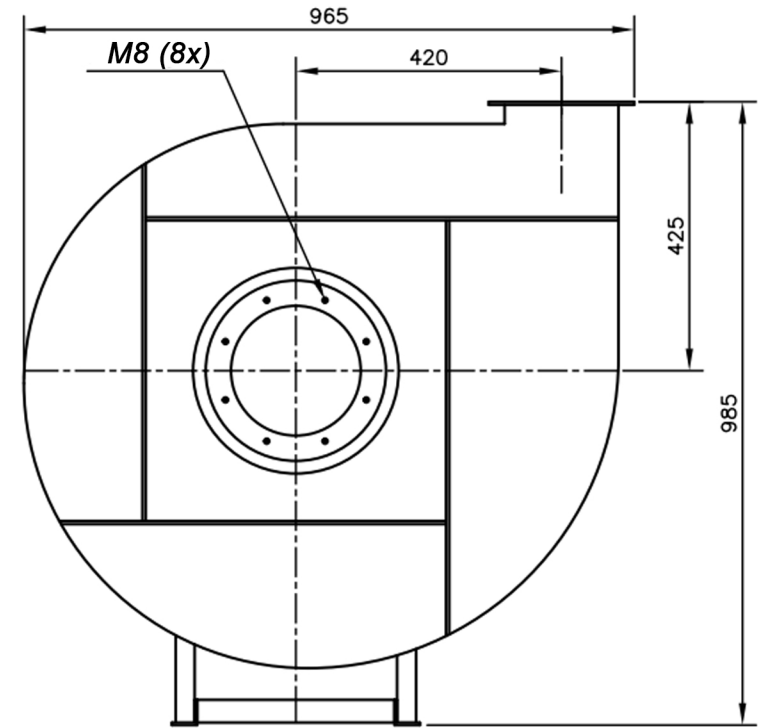
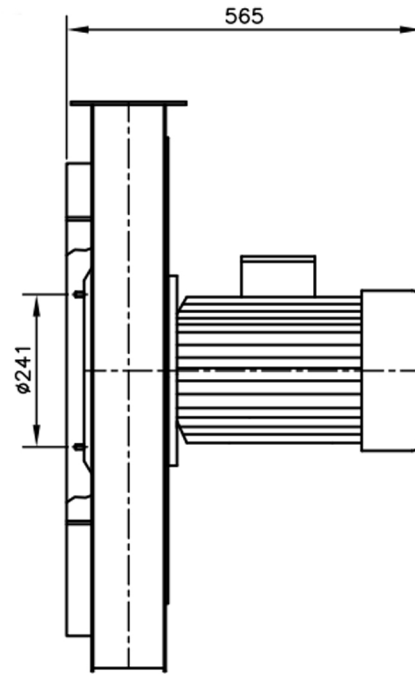
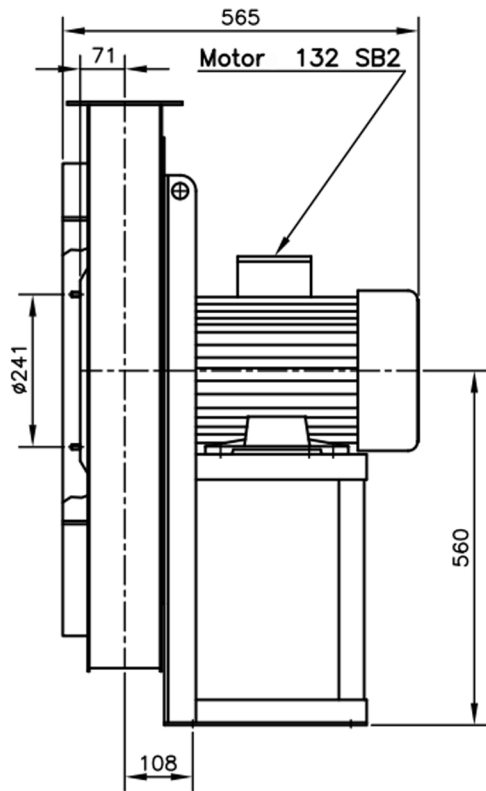

DESCRIPTION-BESCHRIJVING TF631/B - RD0	SCHAAL 1:12	GEMAAKT - PREPARED Overmeer E.	FORMAAT A4
	DATUM 29/11/2023		REV. 00
N. TEKENING - N. DRAWING		V1TF631/B	



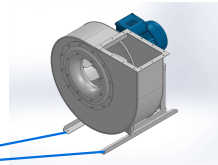
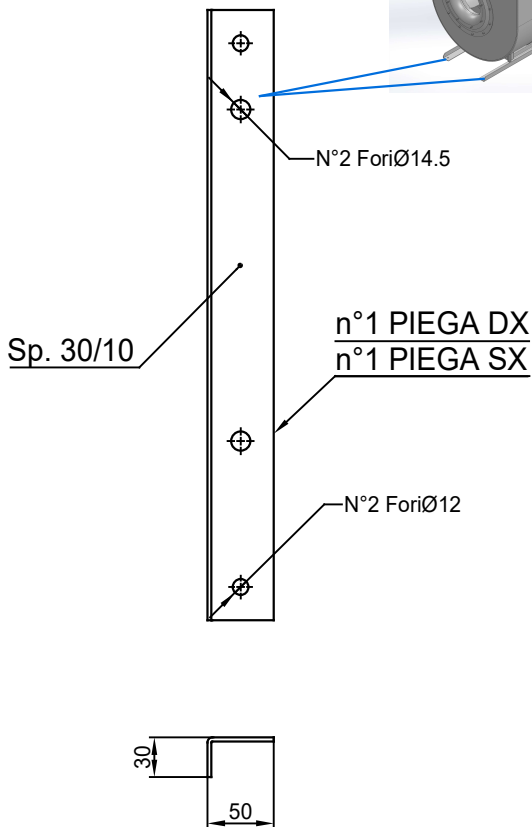
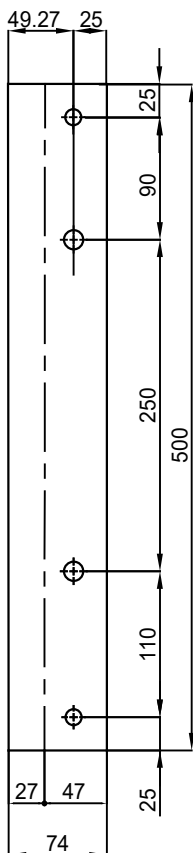

COMM.
N°

00	02/02/2016	PRIMA EMISSIONE	RK	RK
01	16/09/2020	Extension pedestal	MvS	MvS
REV	DATA - DATE	DESCRIZIONE - DESCRIPTION	DISEGNATO PREPARED	CONTROLLATO CHECKED
DESCRIZIONE - DESCRIPTION		MATERIALE - MATERIAL	NR. FILE	PESO - WEIGHT
DESCRIZIONE - DESCRIPTION		Fe 360	SCALA 1:4	DISEGNATO - PREPARED
Staffe per Puffer L=500			DATA 02/02/2016	FORMATO A4
IEC 132 / AP series			SOSTITUISCE IL - REPLACED THE N°	
		N. DISEGNO - N. DRAWING	SOSTITUITO DAL - REPLACES BY N°	REV.
STF-AP13201ST		Slingerland ventilatoren		01