

Research Data

Air-flow rate[m ³ /h]	1675
Pressure[Pa]	352.4
Pressure type	Psta
Power supply	all
Density[m ³ /h]	1.205

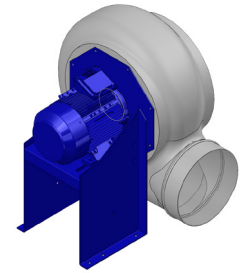

Label

Code	K354
Voltage[V]	400
Phases	3
Current[A]	
Poles	4
Weight[kg]	23
Frequency[Hz]	50
Speed[rpm]	1400
Power[kW]	0.37
IP	55
INS	

Execution:

- Pe moulded housing
- PP impeller
- epoxy painted motor support
- stainless steel screw

Table engines

Class IE	IE1
Size	71
Power[kW]	0.37
Current[A]	1.11
Voltage[V]	400
Cos φ	0.74
n	0.65

Options:

- PP Housing
- INOX/Fe+ebonite impeller
- INOX motor support
- labyrinth seal
- flexible connection PVC
- exhaust cap with grid PP/PVC
- drain plug PP
- motor protection cover
- housing splinter protection PVC
- protection grid INOX
- vibration dampers
- deflector cowl PP/PVC
- gravity damper PP/PVC
- adjustable damper
- silencer PP/PVC

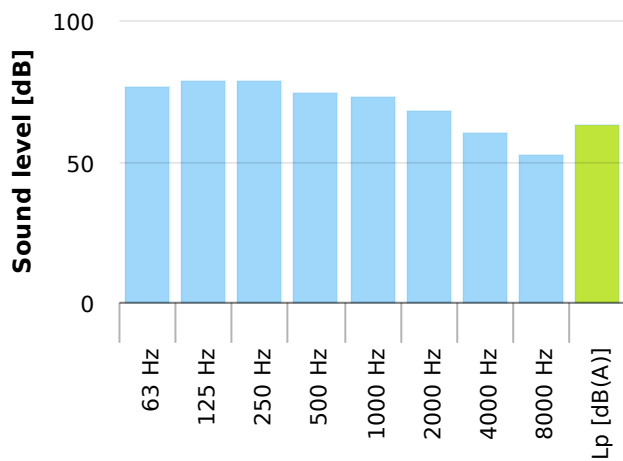
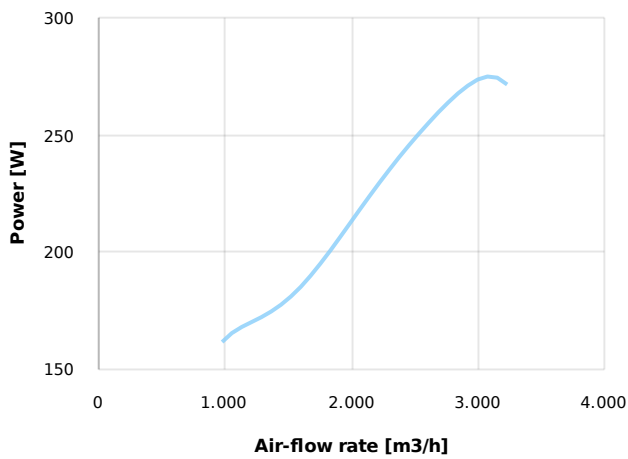
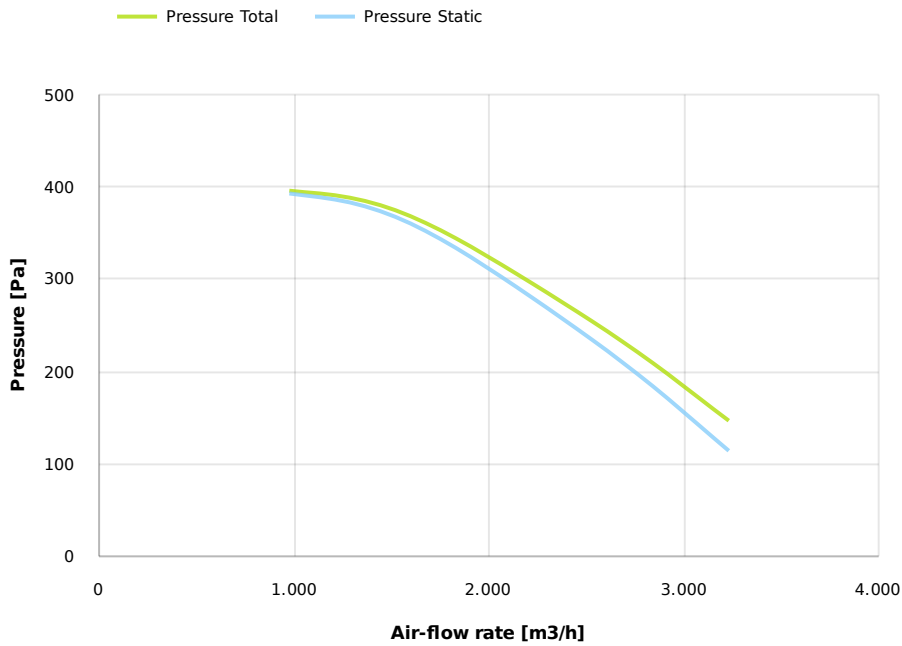

Dimensions

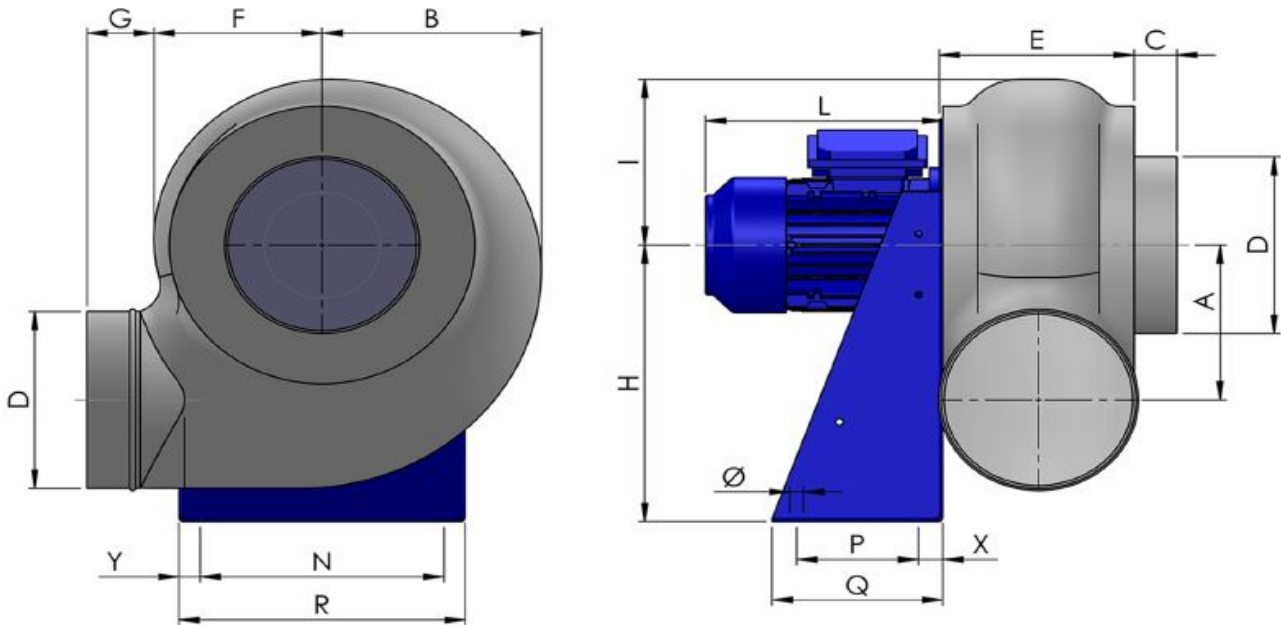

A	B	C	D	E	F	G	H	I	L	N	Ø	P	Q
260	312	40	280	237	230	55	445	270	220	355	11	150	230
		R					X					Y	
		390					40					175	

Configurations & cad

