

Research Data

Air-flow rate[m ³ /h]	439
Pressure[Pa]	118.6
Pressure type	Psta
Power supply	all
Density[m ³ /h]	1.205

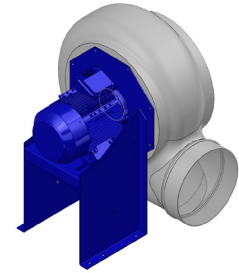

Label

Code	K224
Voltage[V]	400
Phases	3
Current[A]	
Poles	4
Weight[kg]	10
Frequency[Hz]	50
Speed[rpm]	1370
Power[kW]	0.12
IP	55
INS	

Execution:

- Pe moulded housing
- PP impeller
- epoxy painted motor support
- stainless steel screw

Table engines

Class IE	IE1
Size	63
Power[kW]	0.12
Current[A]	0.47
Voltage[V]	400
Cos φ	0.64
n	0.57

Options:

- PP Housing
- INOX/Fe+ebonite impeller
- INOX motor support
- labyrinth seal
- flexible connection PVC
- exhaust cap with grid PP/PVC
- drain plug PP
- motor protection cover
- housing splinter protection PVC
- protection grid INOX
- vibration dampers
- deflector cowl PP/PVC
- gravity damper PP/PVC
- adjustable damper
- silencer PP/PVC

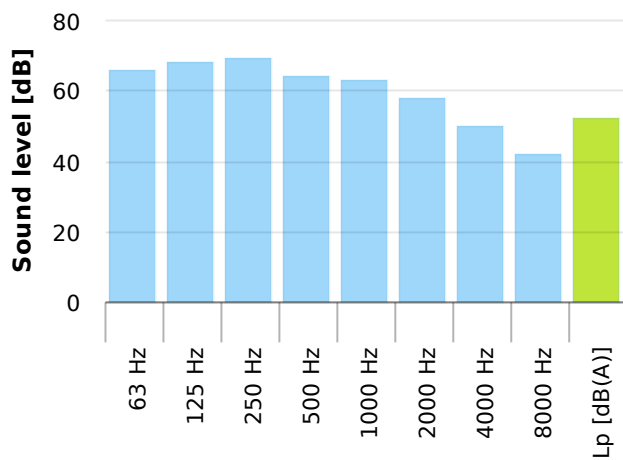
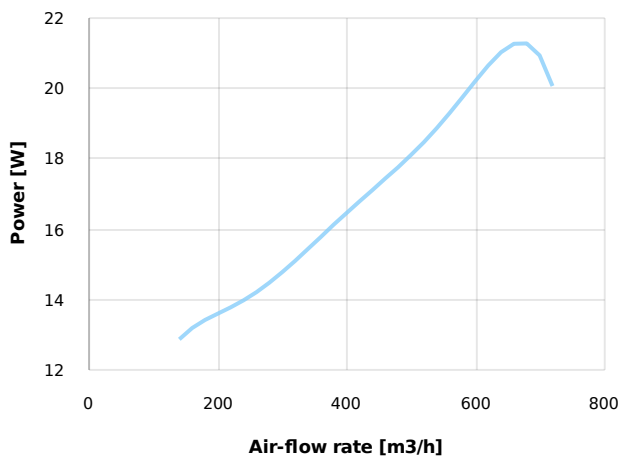
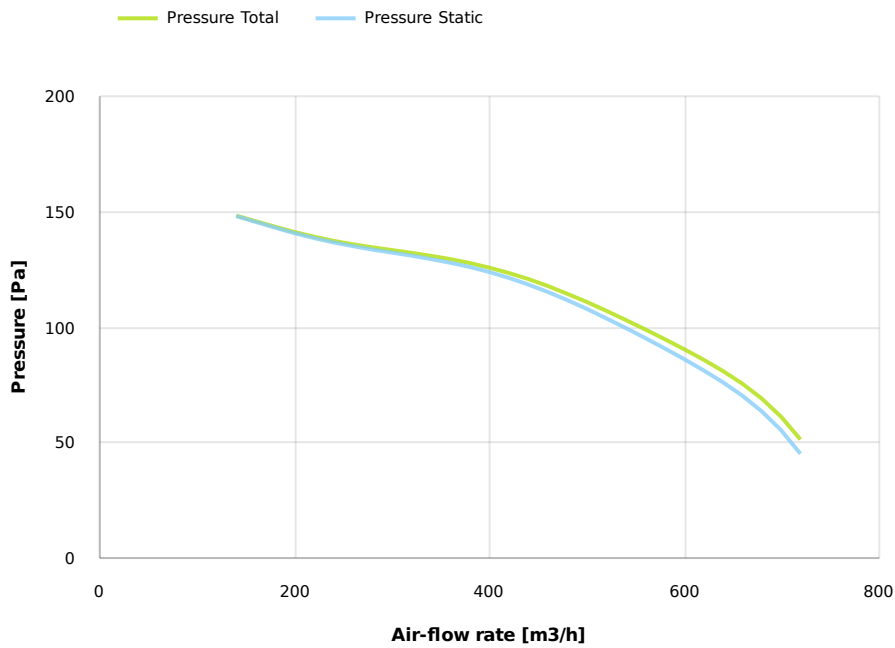

Dimensions

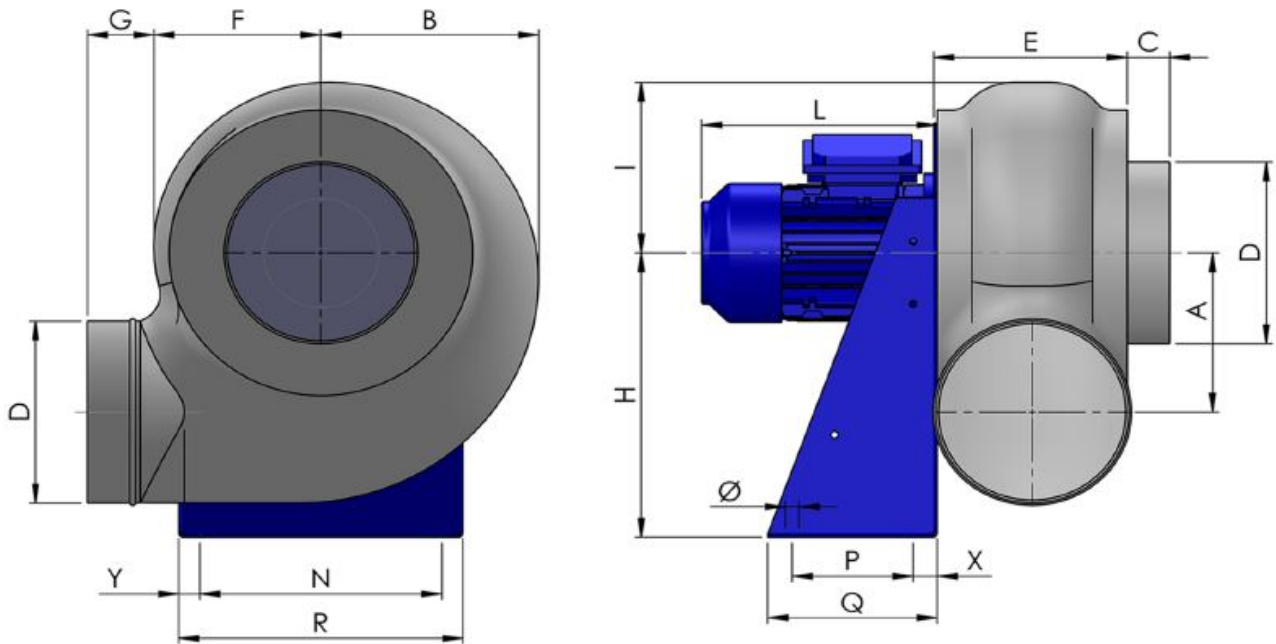

A	B	C	D	E	F	G	H	I	L	N	Ø	P	Q	
173	228	35	200	185	170	55	310	190	190	255	11	100	140	
				R					X					
				290					20					
											Y			
											175			

Configurations & cad

