

EUM 1121

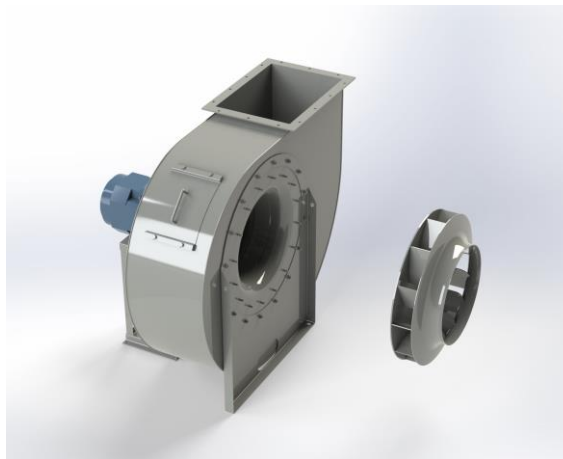

Centrifugal fan model EUM, Es.4

Single inlet fan, direct driven with an IEC-standard motor in form B3 which is mounted on a motorbase. The overhang impeller is mounted on the motor shaft and has backwardly curved blades. The blades are welded between the back plate disc and the aerodynamically formed front plate. The robust industrial fan is totally made of steel and painted in the agate grey color RAL 7037. The fan is suitable for the transportation of clean and slightly dusty air.

General data:

Drive	direct
Motor position	horizontal
Material casing/base	Steel
Material impeller/hub	Steel
Motorcoating/protection	RAL 7037
Operating temperature (max.)	15 (80) °C
Medium density (altitude 0 m)	1,226 kg/m ³
Impeller speed	1485 rpm
Weight	1.449 kg
Sound pressure level ±3	87 dB(A)

(at 1,5 m near the fan with inlet and outlet ducted, in free field)

Electric motor:

	280S	IEC
Power	75	kW
Motor speed	1.485	rpm
Electric supply	3x400V50Hz	V/Hz
Full load current	134	A
Enclosure	55	IP
Shape	B3T	
Efficiency class	IE4	

Curve EUM 1121 @ 1485rpm @ 15°C @ 0m

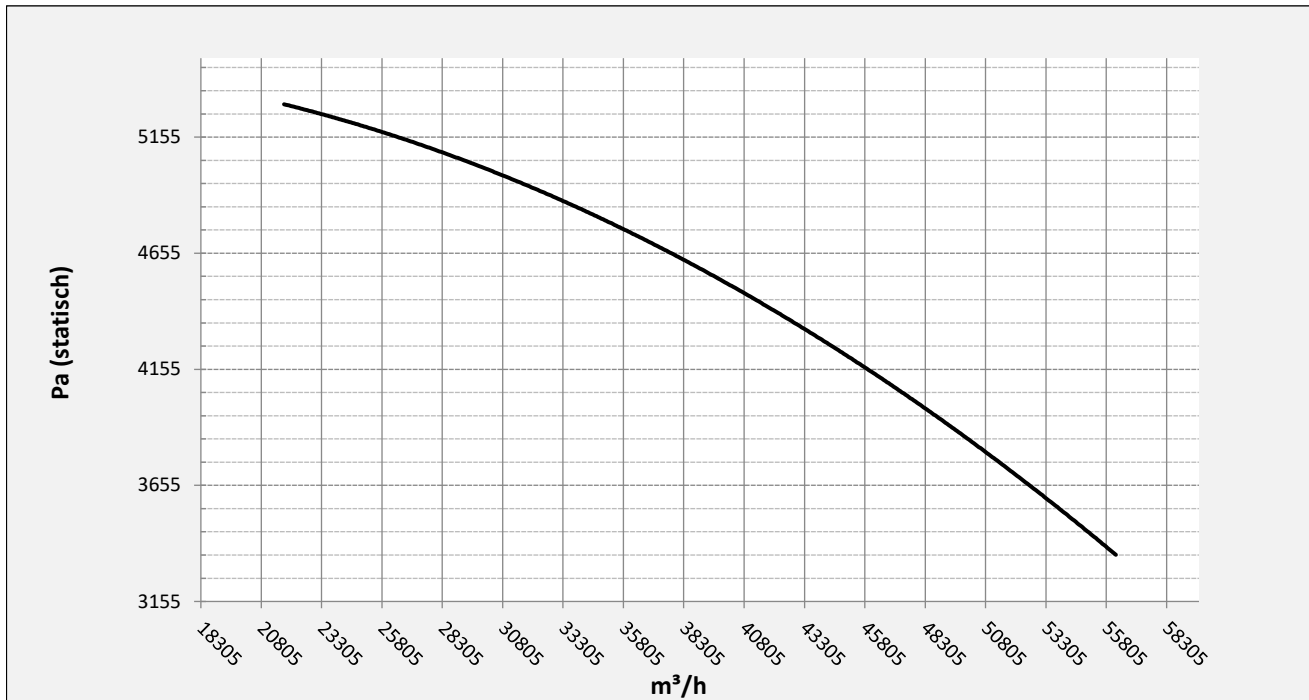

Possible discharge positions:



* (Pos 180 and 225 extra price)

Possible accessories

Mounting profiles for load distribution	--
Counterflange inlet/outlet	zz Ø900 / pz 900x630
Flexible connection inlet/outlet max. 80°C	zz Ø1000 / pz Ø1120
Anti-vibration mountings	6x 100x55/B/40° ShA
Inspectiondoor	
Drain connection	
Shaft seal without asbestos	
Coolingwheel (medium max. 150°C)	(incl. coating RAL9006)
Flexible connection inlet/outlet max. 150°C	zz Ø1000 / pz Ø1120
ATEX version	Zone 1 / 2 / 21 / 22
ATEX motor	Ex nA / Exe / Ex de
Coating suitable for outdoor application	RAL 5010 / RAL
Stainless steel version	304 / 316 / ...
Acoustic enclosure	

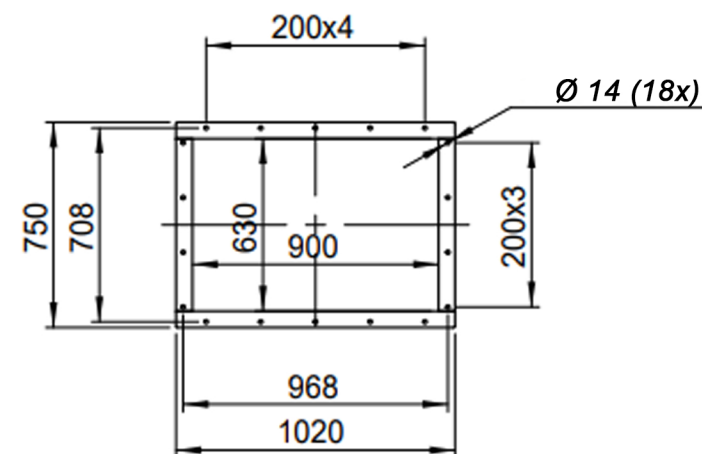
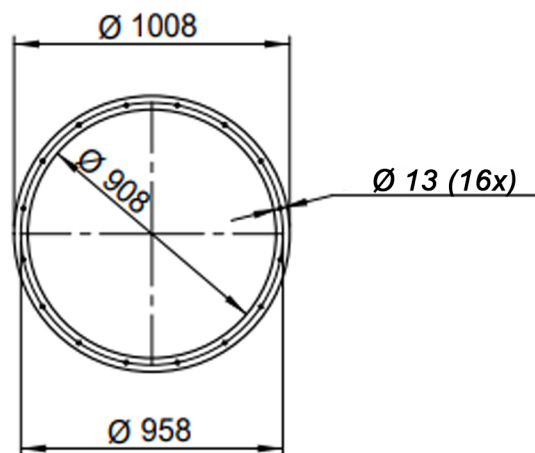
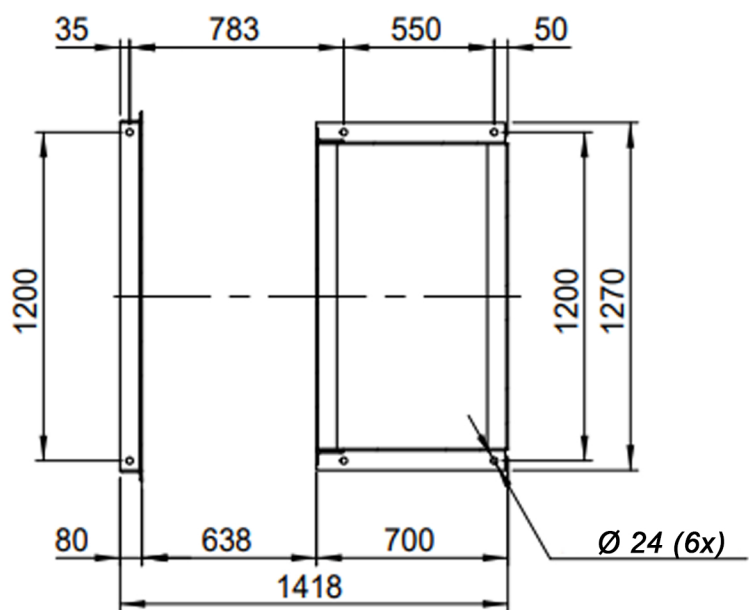
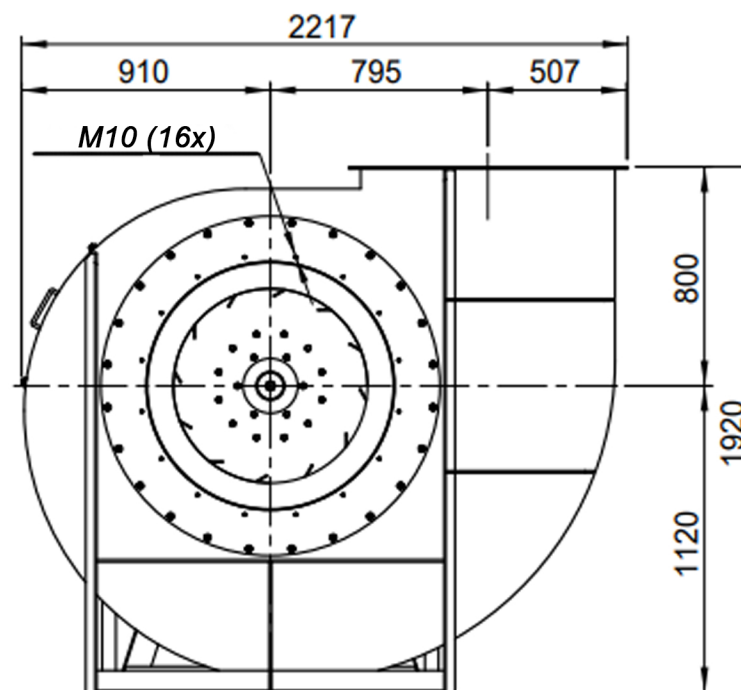
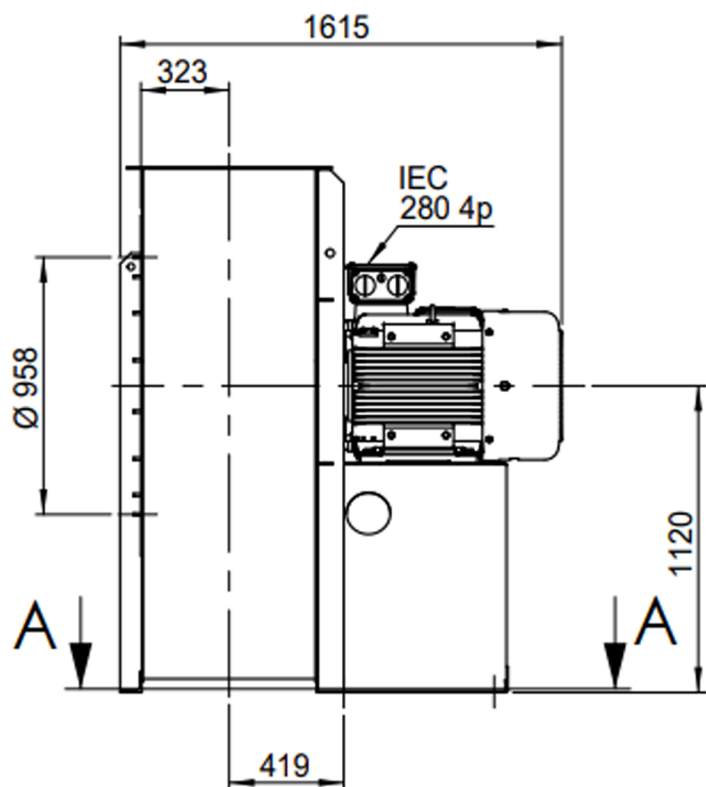

DESCRIPTION-BESCHRIJVING EUM1121 - RD0	SCHAAL 1:28	GEMAAKT - PREPARED Overmeer E.	FORMAAT A4
	DATUM 31/10/2023		REV. 00
Slingerland ventilatoren 		N.TEKENING - N.DRAWING V1EUM 1121	