

## APRI 711B

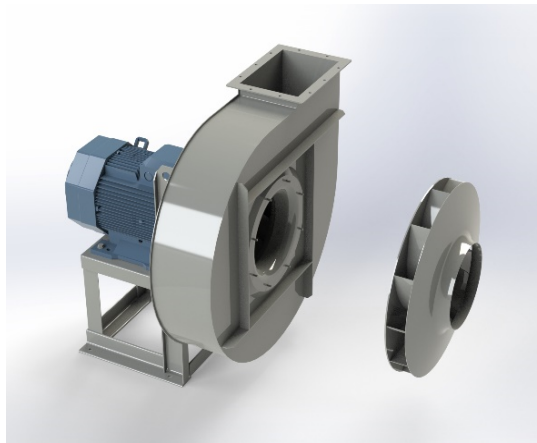

### Centrifugal fan model APRI, Es.4

Single inlet fan, direct driven with an IEC-standard motor in form B3 which is mounted on a motorbase. This series of high-pressure fans is characterized by a high efficiency with electricity saving by installing a special impeller with backward curved blades. The robust industrial fan is totally made of steel and painted in the agate gray RAL 7037. The fan is suitable for the transportation of clean and slightly dusty air.

#### General data:

Drive	direct
Motor position	horizontal
Material casing/base	Steel
Material impeller/hub	Steel
Motorcoating/protection	RAL 7037
Operating temperature (max.)	15 (80) °C
Medium density (altitude 0 m)	1,226 kg/m <sup>3</sup>
Impeller speed	2960 rpm
Weight	479 kg
Sound pressure level ±3	92 dB(A)

*(at 1,5 m near the fan with inlet and outlet ducted, in free field)*

#### Electric motor:

	200L	IEC
Power	37	kW
Motor speed	2.960	rpm
Electric supply	3x400V50Hz	V/Hz
Full load current	67,8	A
Enclosure	55	IP
Shape	B3T	
Efficiency class	IE3	

**Curve APRI 711B @ 2960rpm @ 15°C @ 0m**

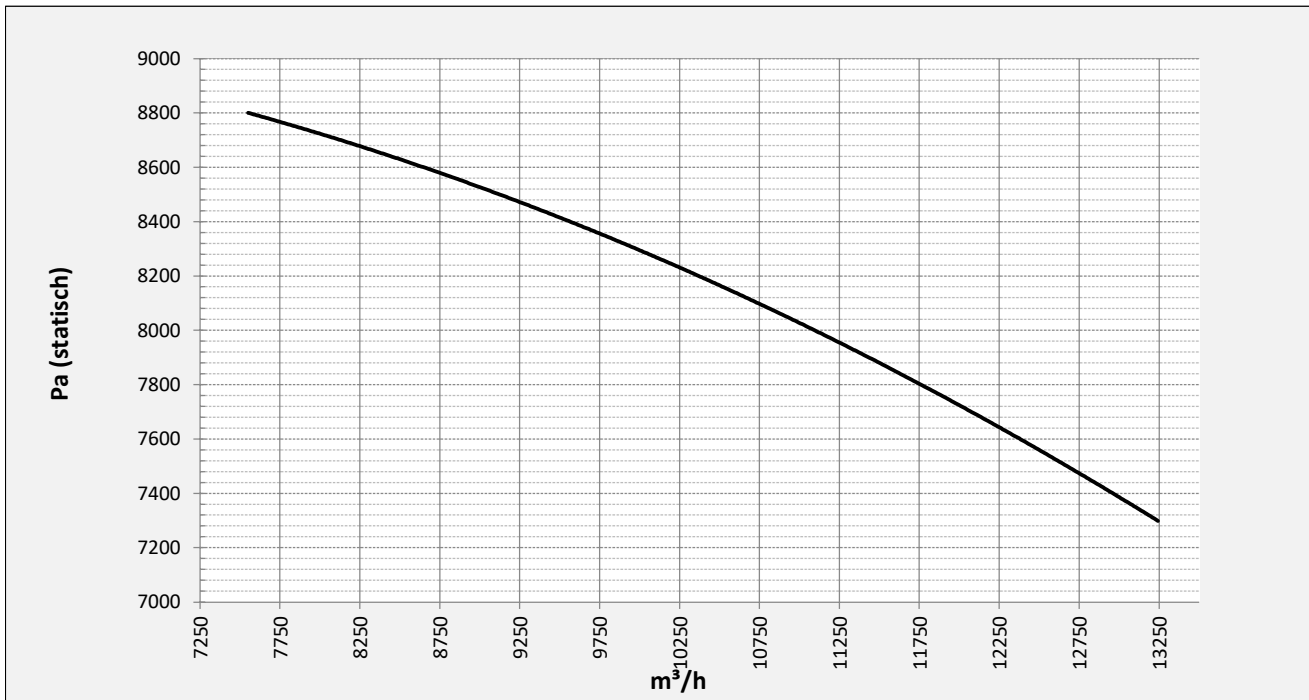

**Possible discharge positions:**

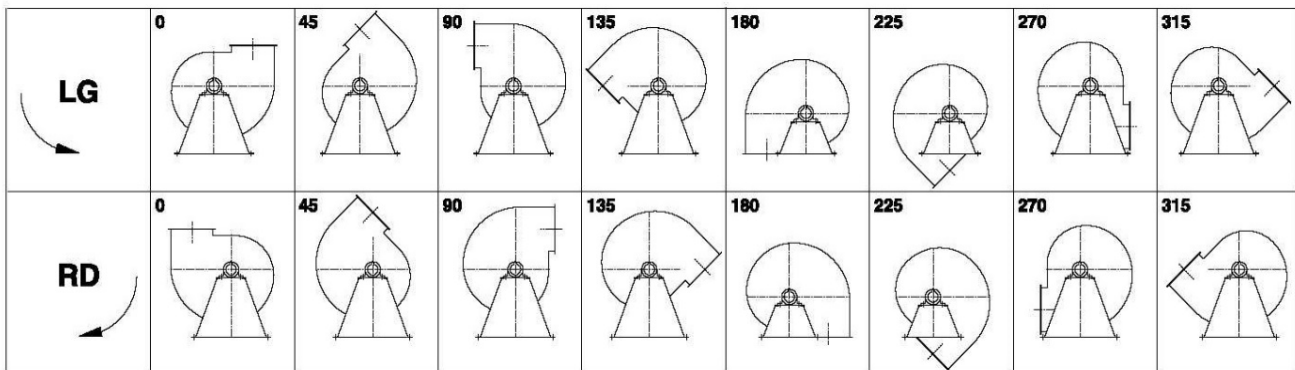

\* (Pos 180 and 225 extra price)

**Possible accessories**

Mounting profiles for load distribution	AP20001ST
Counterflange inlet/outlet	zz Ø400 / pz 400x280
Flexible connection inlet/outlet max. 80°C	zz Ø450 / pz Ø500
Anti-vibration mountings	4x 70X45/B/70° ShA
Inspection door	
Drain connection	
Shaft seal without asbestos	
Cooling wheel (medium max. 150°C)	( incl. coating RAL9006 )
Flexible connection inlet/outlet max. 150°C	zz Ø450 / pz Ø500
ATEX version	Zone 1 / 2 / 21 / 22
ATEX motor	Ex nA / Exe / Ex de
Coating suitable for outdoor application	RAL 5010 / RAL ....
Stainless steel version	304 / 316 / ...
Acoustic enclosure	

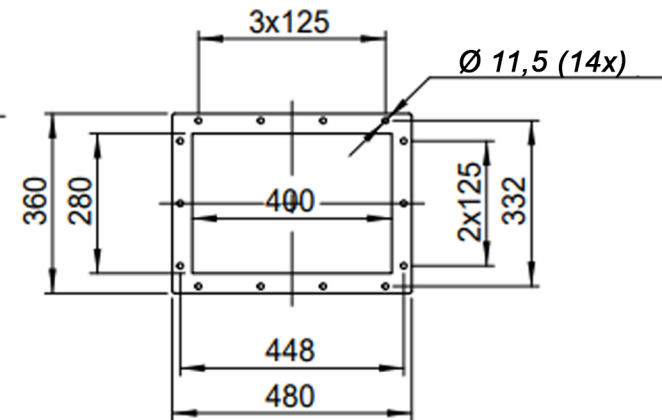
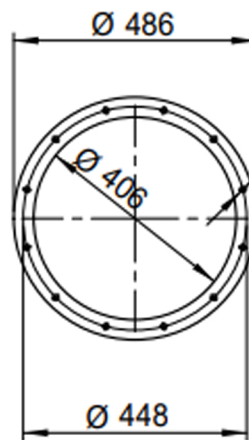
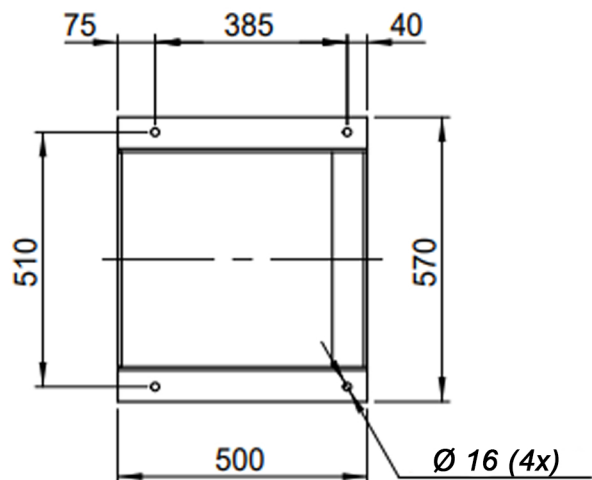
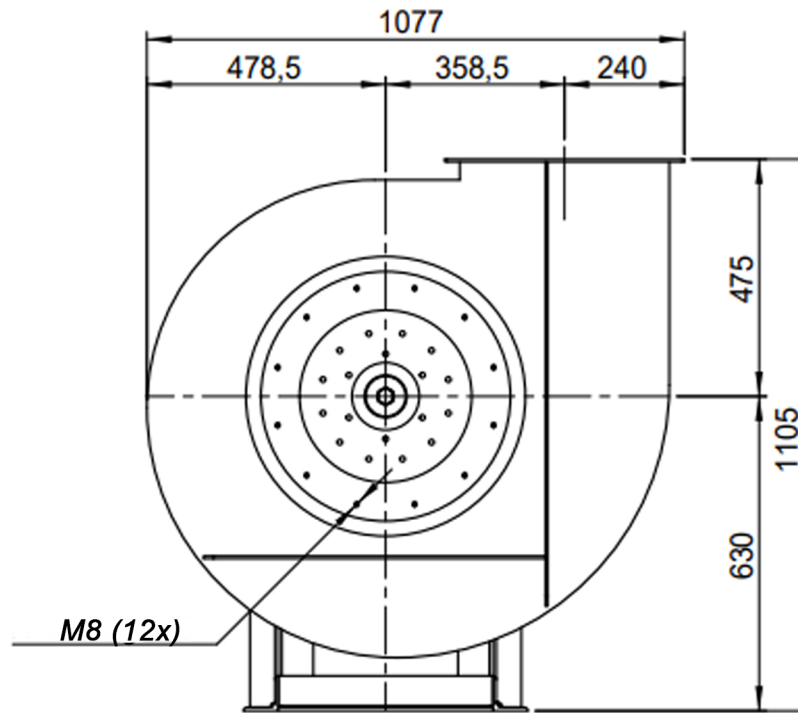
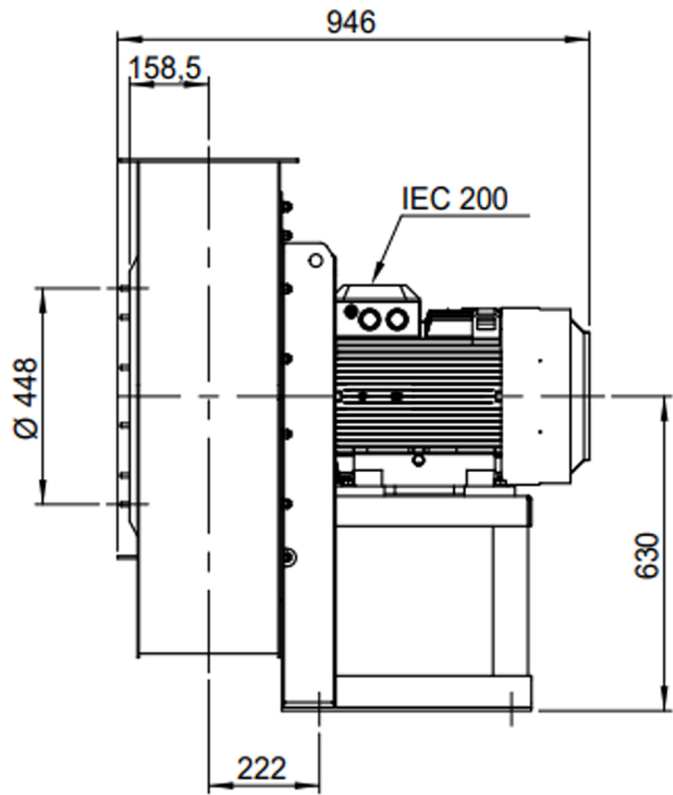

DESCRIPTION-BESCHRIJVING <b>APRI711/B - RD0</b>	SCHAAL 1:15	GEMAAKT - PREPARED Overmeer E.	FORMAAT A4
	DATUM 29/11/2023		REV. 00
N.TEKENING - N.DRAWING <b>Slingerland ventilatoren</b>		V1APRI711/B	

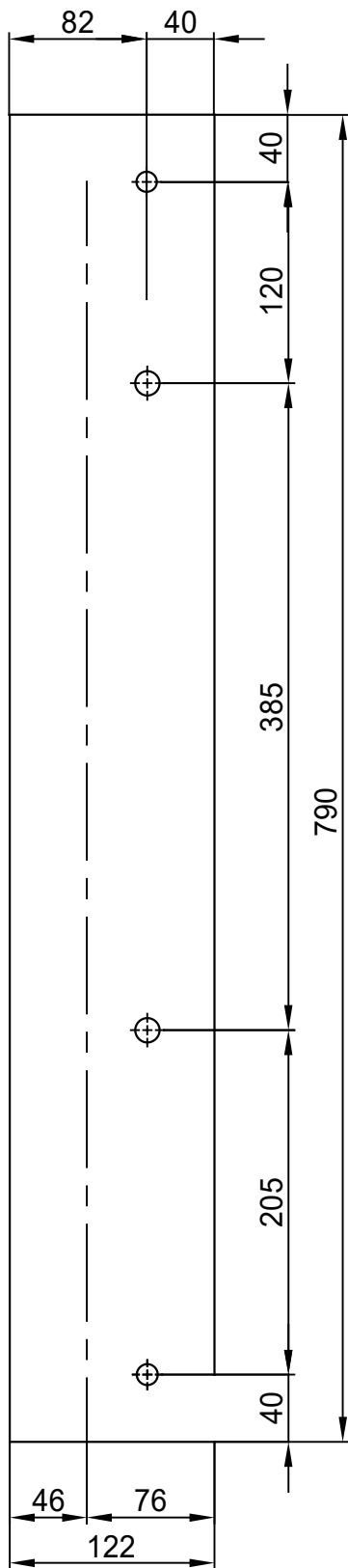

Sp. 40/10

N°2 ForoØ14.5

n°1 PIEGA DX  
n°1 PIEGA SX

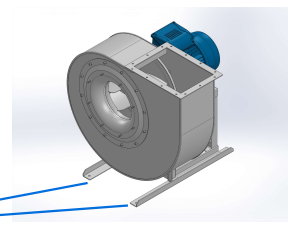

COMM.  
N°

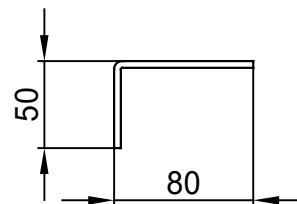

N°2 ForiØ12.5

00	04/02/2016	PRIMA EMISSIONE	RK	RK
REV	DATA - DATE	DESCRIZIONE - DESCRIPTION	DISEGNATO PREPARED	APPROVATO APPROVED
DESCRIZIONE - DESCRIPTION		MATERIALE - MATERIAL	NR.FILE	PESO - WEIGHT
		Fe 360		Kg
DESCRIZIONE - DESCRIPTION		SCALA	DISEGNATO - PREPARED	FORMATO
Staffe per Puffer L=750		1:4.5	RK	A4
IEC 200 / AP series		DATA	SOSTITUISCE IL - REPLACES THE N°	
		04/02/2016	SOSTITUITO DAL - REPLACES BY N°	
N.DISEGNO - N.DRAWING			REV.	
STF-AP20001ST			01	

