

## APRG 1002B

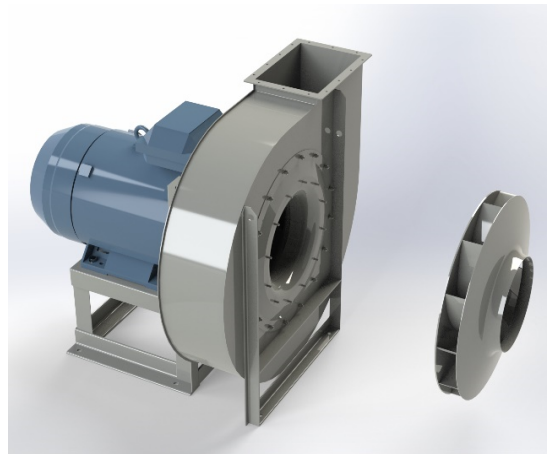

### Centrifugal fan model APRG, Es.4

Single inlet fan, direct driven with an IEC-standard motor in form B3 which is mounted on a motorbase. This series of high-pressure fans is characterized by a high efficiency with electricity saving by installing a special impeller with backward curved blades. The robust industrial fan is totally made of steel and painted in the agate gray RAL 7037. The fan is suitable for the transportation of clean and slightly dusty air.

#### General data:

Drive	direct
Motor position	horizontal
Material casing/base	Steel
Material impeller/hub	Steel
Motorcoating/protection	RAL 7037
Operating temperature (max.)	15 (80) °C
Medium density (altitude 0 m)	1,226 kg/m <sup>3</sup>
Impeller speed	2980 rpm
Weight	1.364 kg
Sound pressure level ±3	95 dB(A)

*(at 1,5 m near the fan with inlet and outlet ducted, in free field)*

#### Electric motor:

	315S	IEC
Power	110	kW
Motor speed	2.980	rpm
Electric supply	3x400V50Hz	V/Hz
Full load current	189	A
Enclosure	55	IP
Shape	B3T	
Efficiency class	IE4	

**Curve APRG 1002B @ 2980rpm @ 15°C @ 0m**



**Possible discharge positions:**



\* (Pos 180 and 225 extra price)

**Possible accessories**

Mounting profiles for load distribution	--
Counterflange inlet/outlet	zz Ø400 / pz 355x250
Flexible connection inlet/outlet max. 80°C	zz Ø450 / pz Ø450
Anti-vibration mountings	6x 100x55/B/70° ShA
Inspectiondoor	
Drain connection	
Shaft seal without asbestos	
Coolingwheel (medium max. 150°C)	( incl. coating RAL9006 )
Flexible connection inlet/outlet max. 150°C	zz Ø450 / pz Ø450
ATEX version	Zone 1 / 2 / 21 / 22
ATEX motor	Ex nA / Exe / Ex de
Coating suitable for outdoor application	RAL 5010 / RAL ....
Stainless steel version	304 / 316 / ...
Acoustic enclosure	

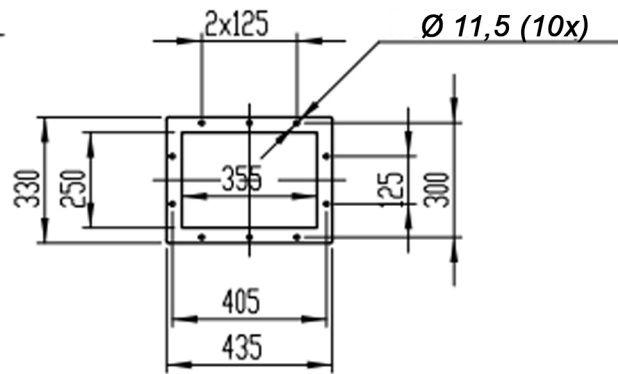
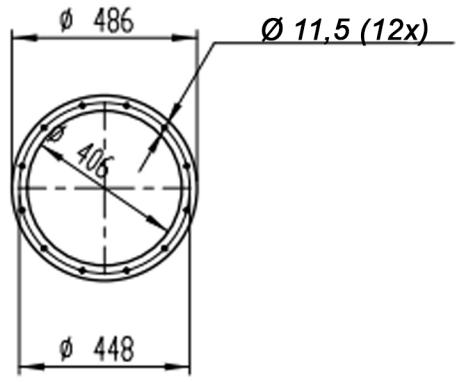
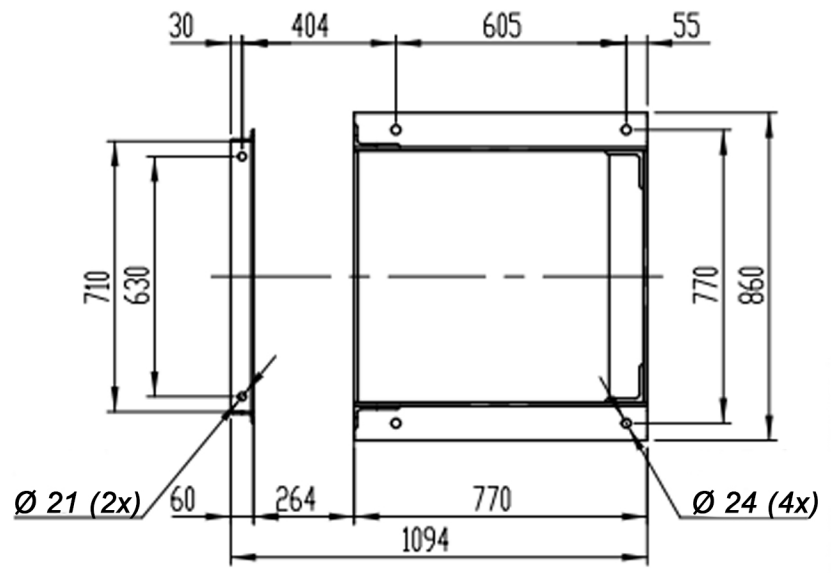
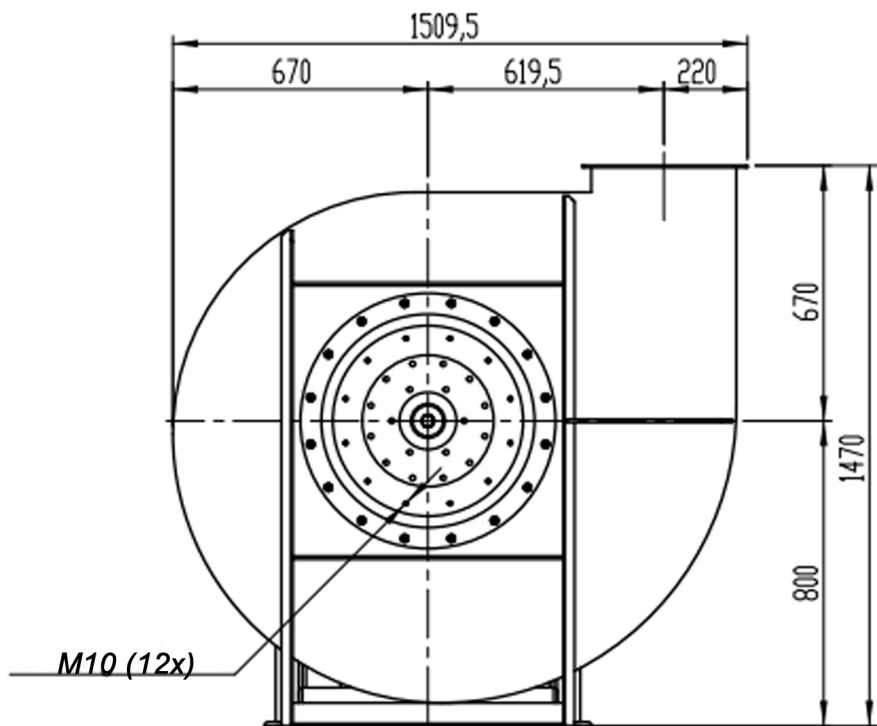
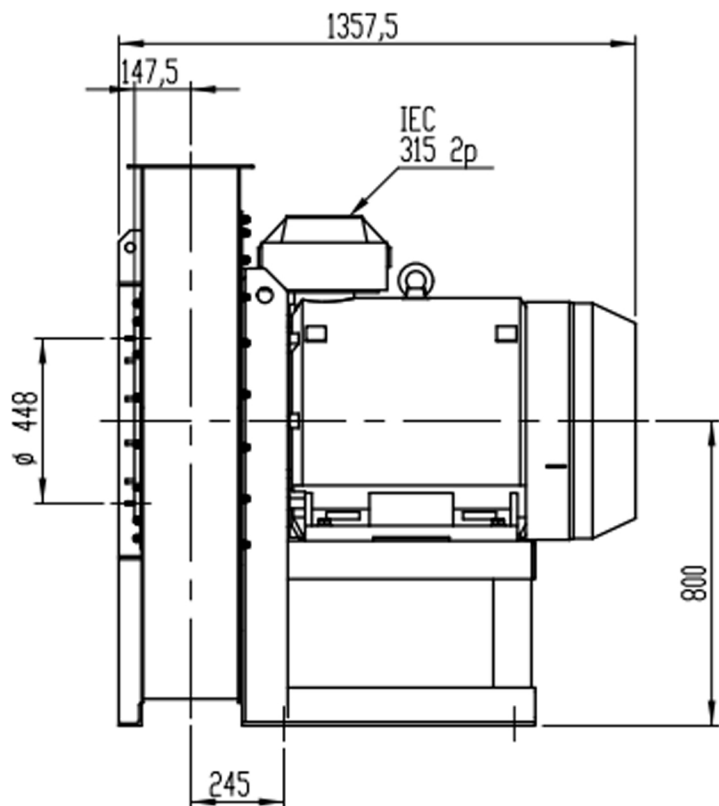

DESCRIPTION-BESCHRIJVING	SCHAAL	GEMAAKT - PREPARED	FORMAAT
<b>APRG1002/B - RD0</b>	1:20	Overmeer E.	A4
	DATUM		
	17/11/2023		
Slingerland ventilatoren		N.TEKENING - N.DRAWING	REV.
		<b>V1APRG1002/B</b>	00