

APRF 712B

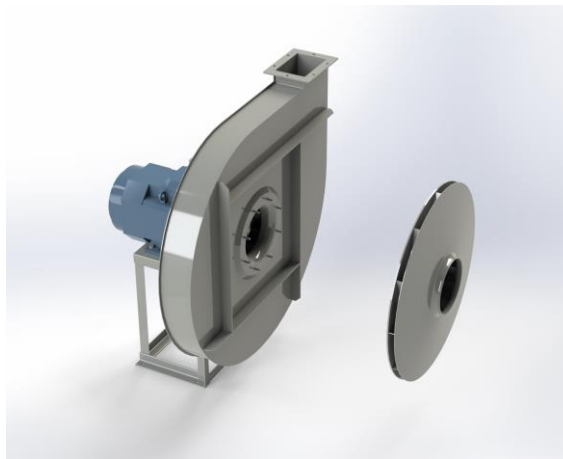

Centrifugal fan model APRF, Es.4

Single inlet fan, direct driven with an IEC-standard motor in form B3 which is mounted on a motorbase. This series of high-pressure fans is characterized by a high efficiency with electricity saving by installing a special impeller with backward curved blades. The robust industrial fan is totally made of steel and painted in the agate gray RAL 7037. The fan is suitable for the transportation of clean and slightly dusty air.

General data:

Drive	direct
Motor position	horizontal
Material casing/base	Steel
Material impeller/hub	Steel
Motorcoating/protection	RAL 7037
Operating temperature (max.)	15 (80) °C
Medium density (altitude 0 m)	1,226 kg/m ³
Impeller speed	2930 rpm
Weight	184 kg
Sound pressure level ±3	83 dB(A)

(at 1,5 m near the fan with inlet and outlet ducted, in free field)

Electric motor:

	132S	IEC
Power	7,5	kW
Motor speed	2.930	rpm
Electric supply	3x400V50Hz	V/Hz
Full load current	14,1	A
Enclosure	55	IP
Shape	B3T	
Efficiency class	IE3	

Curve APRF 712B @ 2930rpm @ 15°C @ 0m

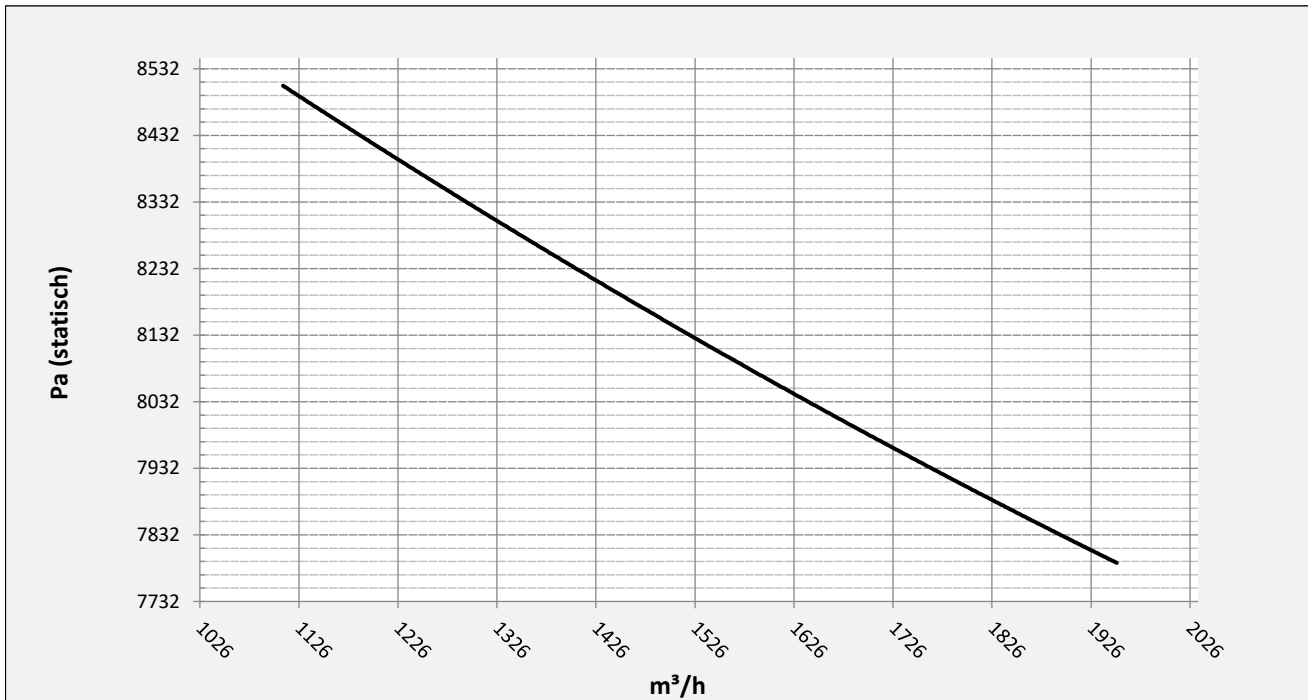

Possible discharge positions:

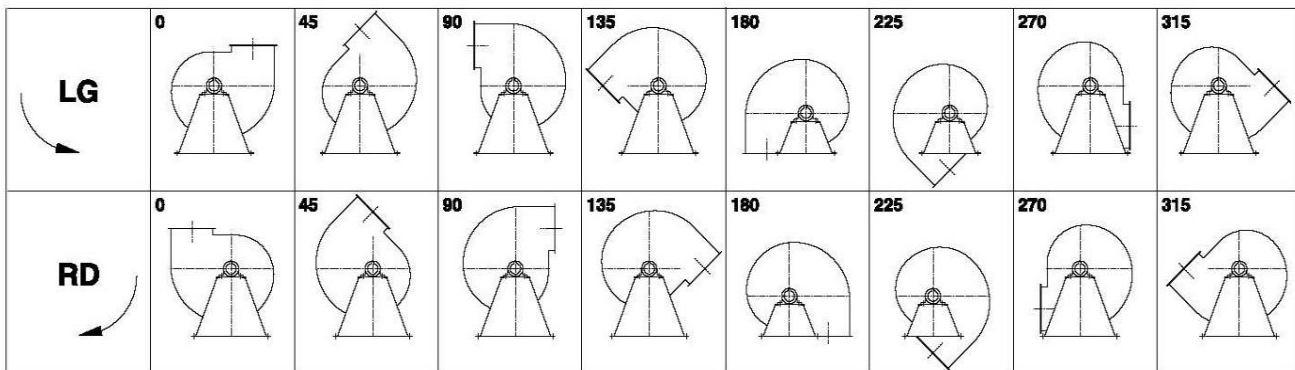

* (Pos 180 and 225 extra price)

Possible accessories

Mounting profiles for load distribution	--
Counterflange inlet/outlet	zz Ø224 / pz 180x125
Flexible connection inlet/outlet max. 80°C	zz Ø250 / pz Ø250
Anti-vibration mountings	4x 40x30/B/70° ShA
Inspectiondoor	
Drain connection	
Shaft seal without asbestos	
Coolingwheel (medium max. 150°C)	(incl. coating RAL9006)
Flexible connection inlet/outlet max. 150°C	zz Ø250 / pz Ø250
ATEX version	Zone 1 / 2 / 21 / 22
ATEX motor	Ex nA / Exe / Ex de
Coating suitable for outdoor application	RAL 5010 / RAL
Stainless steel version	304 / 316 / ...
Acoustic enclosure	

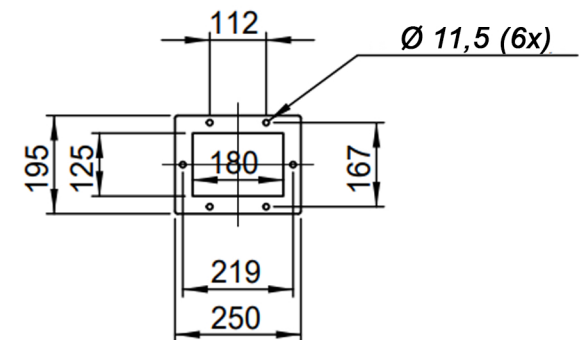
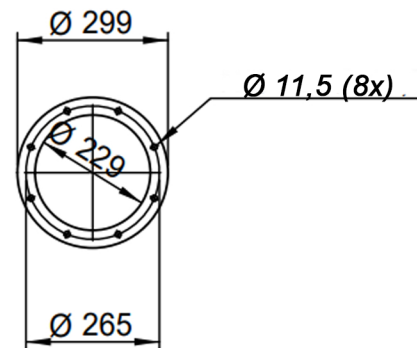
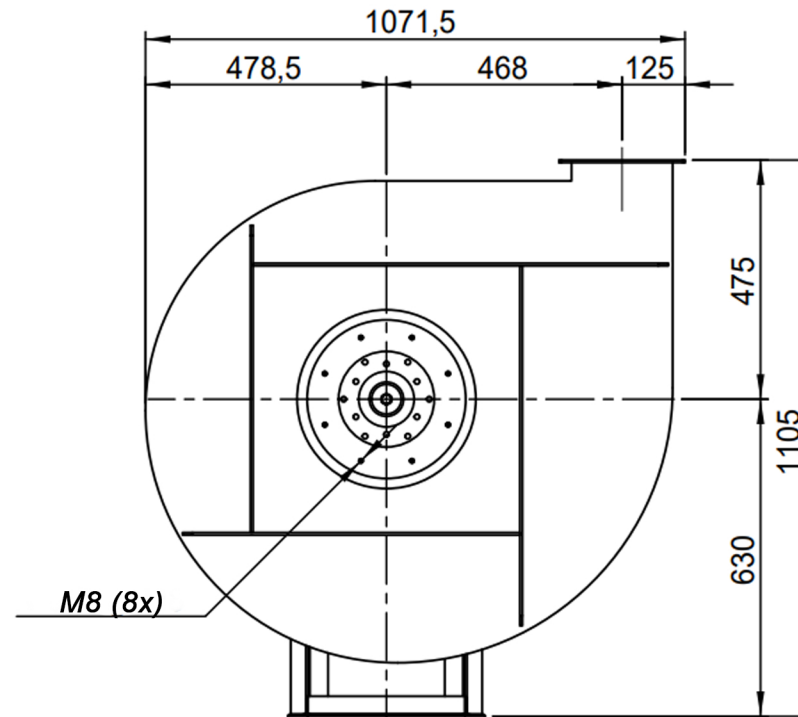
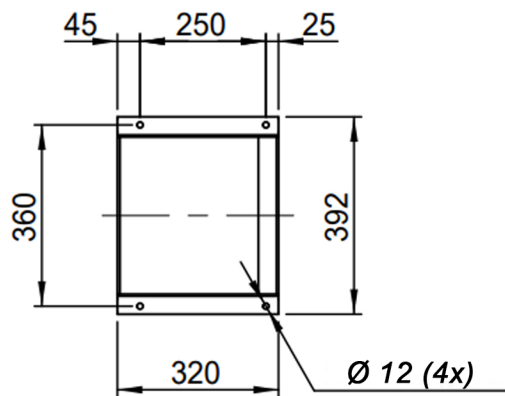
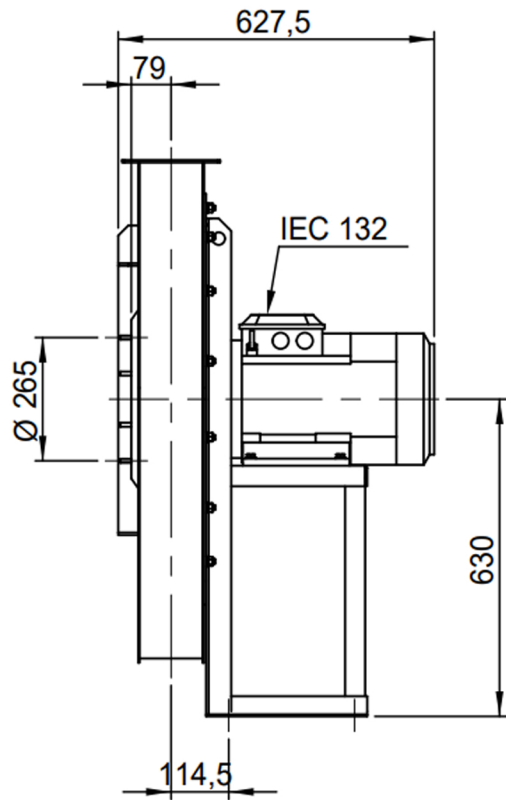

DESCRIPTION-BESCHRIJVING APRF712/B - RD0	SCHAAL 1:15	GEMAAKT - PREPARED Overmeer E.	FORMAAT A4
	DATUM 15/11/2023		
N.TEKENING - N.DRAWING 		REV. 00	
		V1APRF712/B	

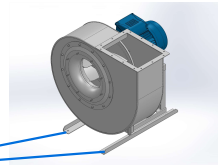
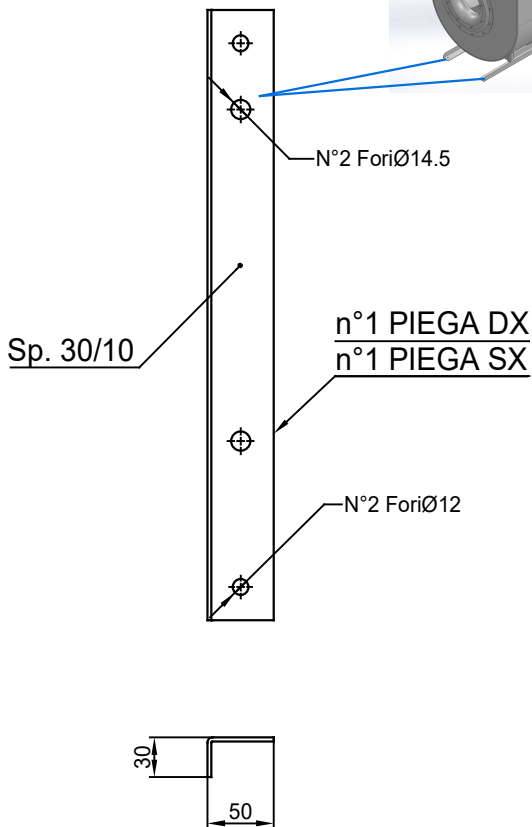
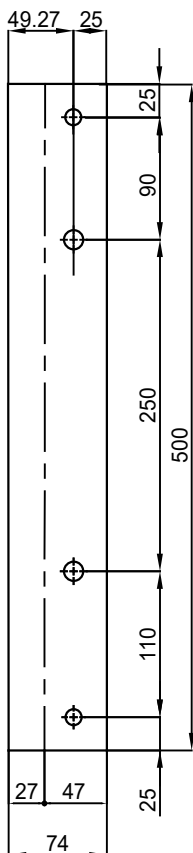

COMM.
N°

00	02/02/2016	PRIMA EMISSIONE		RK	RK
01	16/09/2020	Extension pedestal		MvS	MvS
REV	DATA - DATE	DESCRIZIONE - DESCRIPTION		DISEGNATO PREPARED	CONTROLLATO CHECKED
DESCRIZIONE - DESCRIPTION		MATERIALE - MATERIAL	NR. FILE	PESO - WEIGHT	
DESCRIZIONE - DESCRIPTION		Fe 360		Kg	
Staffe per Puffer L=500 IEC 132 / AP series			SCALA 1:4	DISEGNATO - PREPARED	FORMATO
			DATA 02/02/2016	RK	A4
			SOSTITUISCE IL - REPLACES THE N° SOSTITUITO DAL - REPLACES BY N°		
N. DISEGNO - N. DRAWING			Slingerland ventilatoren		REV.
STF-AP13201ST					01