

## APRF 631B

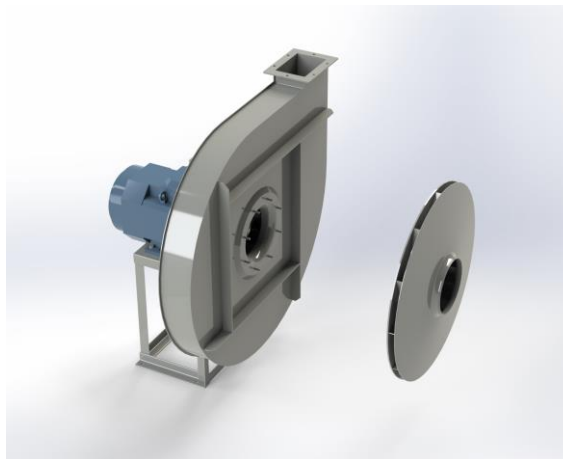

### Centrifugal fan model APRF, Es.4

Single inlet fan, direct driven with an IEC-standard motor in form B3 which is mounted on a motorbase. This series of high-pressure fans is characterized by a high efficiency with electricity saving by installing a special impeller with backward curved blades. The robust industrial fan is totally made of steel and painted in the agate gray RAL 7037. The fan is suitable for the transportation of clean and slightly dusty air.

#### General data:

Drive	direct
Motor position	horizontal
Material casing/base	Steel
Material impeller/hub	Steel
Motorcoating/protection	RAL 7037
Operating temperature (max.)	15 (80) °C
Medium density (altitude 0 m)	1,226 kg/m <sup>3</sup>
Impeller speed	2940 rpm
Weight	150 kg
Sound pressure level ±3	82 dB(A)

*(at 1,5 m near the fan with inlet and outlet ducted, in free field)*

#### Electric motor:

	132S	IEC
Power	5,5	kW
Motor speed	2.940	rpm
Electric supply	3x400V50Hz	V/Hz
Full load current	10,6	A
Enclosure	55	IP
Shape	B3T	
Efficiency class	IE3	

Curve APRF 631B @ 2940rpm @ 15°C @ 0m

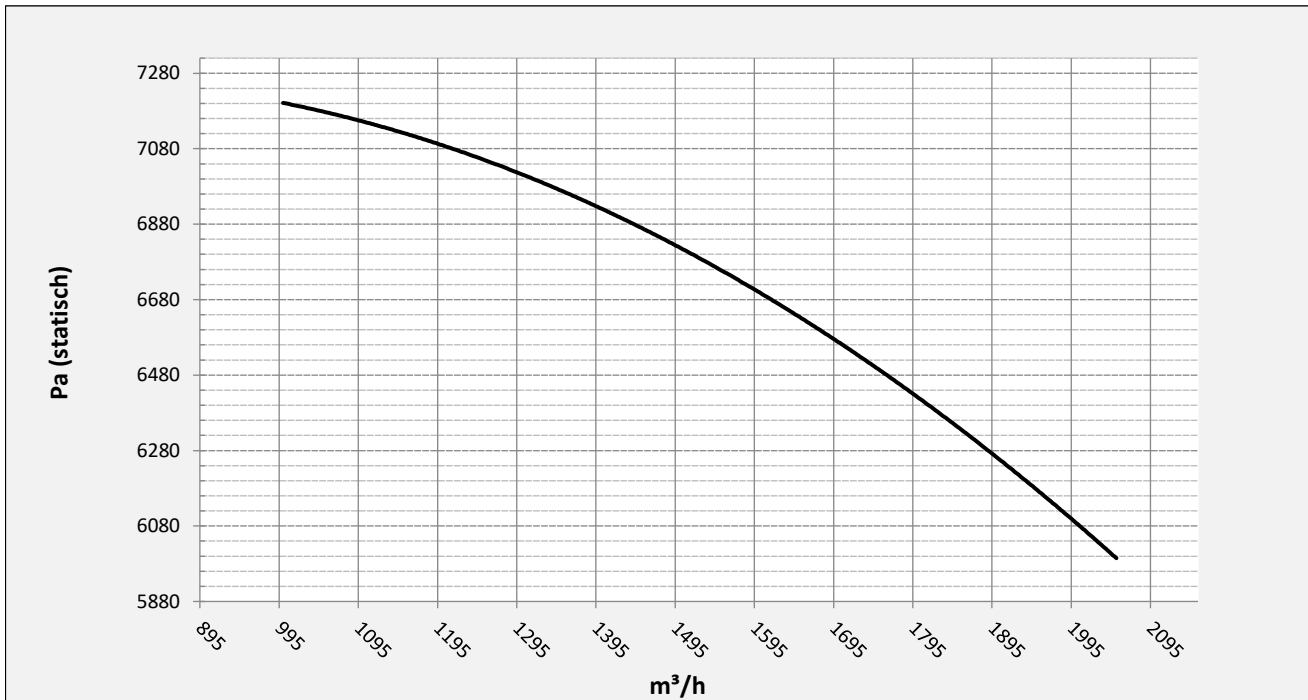

Possible discharge positions:



\* (Pos 180 and 225 extra price)

Possible accessories

Mounting profiles for load distribution	--
Counterflange inlet/outlet	zz Ø200 / pz 160x112
Flexible connection inlet/outlet max. 80°C	zz Ø250 / pz Ø250
Anti-vibration mountings	4x 40x30/B/70° ShA
Inspection door	
Drain connection	
Shaft seal without asbestos	
Cooling wheel (medium max. 150°C)	( incl. coating RAL9006 )
Flexible connection inlet/outlet max. 150°C	zz Ø250 / pz Ø250
ATEX version	Zone 1 / 2 / 21 / 22
ATEX motor	Ex nA / Exe / Ex de
Coating suitable for outdoor application	RAL 5010 / RAL ....
Stainless steel version	304 / 316 / ...
Acoustic enclosure	

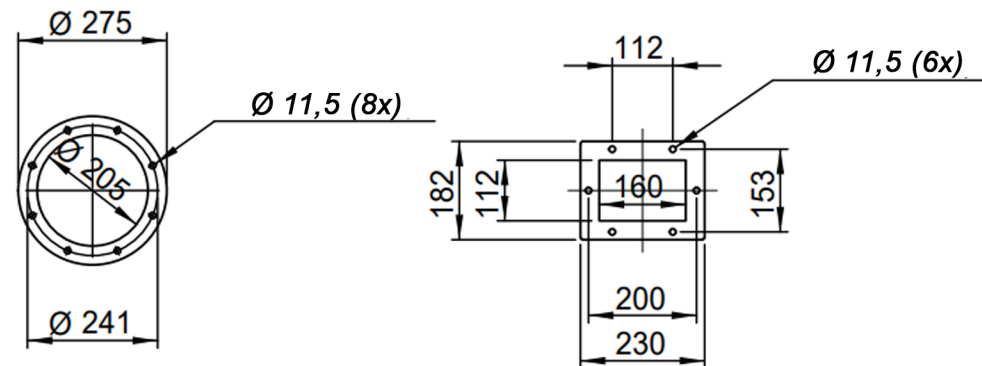
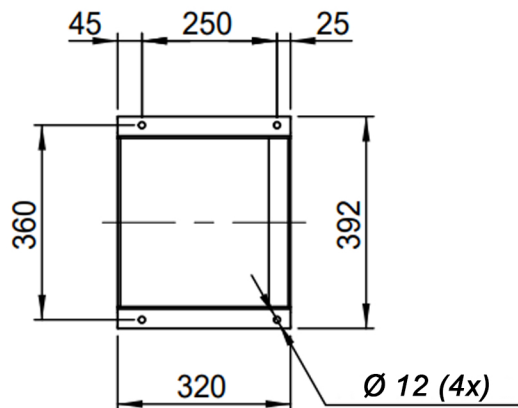
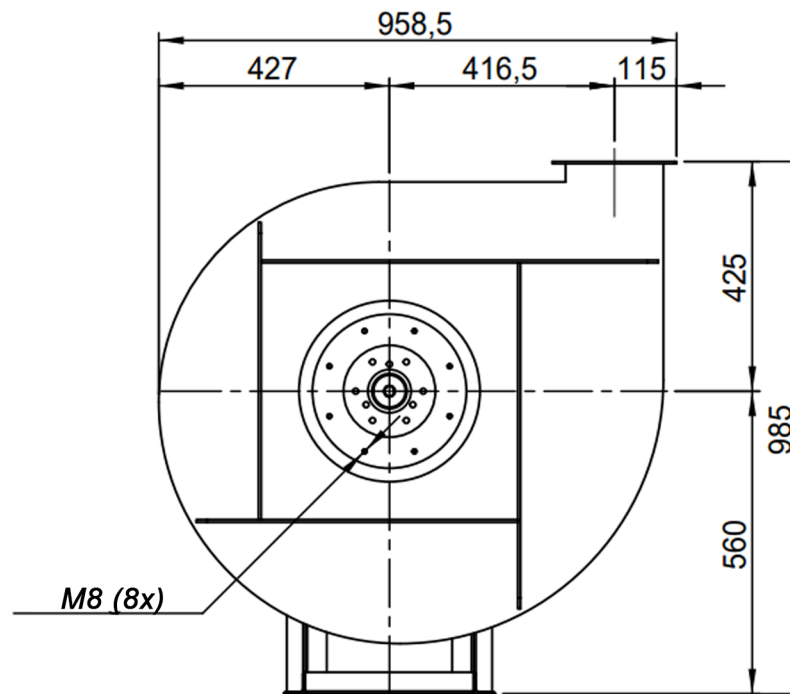
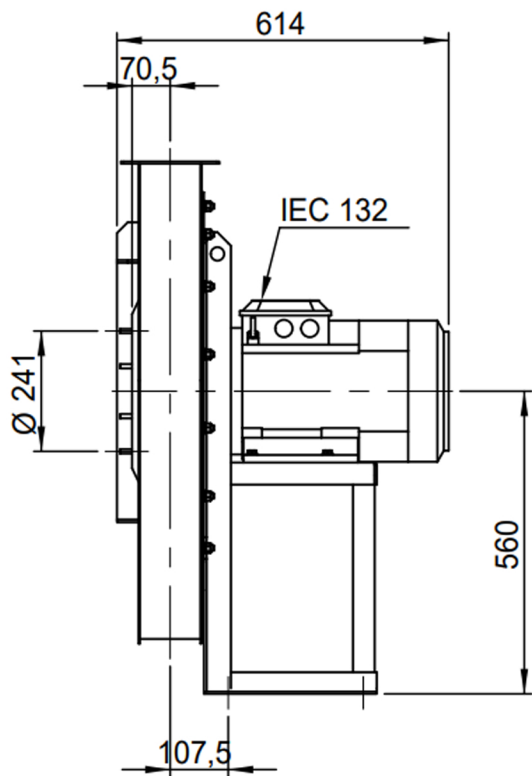

DESCRIPTION-BESCHRIJVING <b>APRF631/B - RD0</b>	SCHAAL <b>1:14</b>	GEMAAKT - PREPARED <b>Overmeer E.</b>	FORMAAT <b>A4</b>
	DATUM <b>15/11/2023</b>		REV. <b>00</b>
N.TEKENING - N.DRAWING <b>Slingerland ventilatoren</b>		<b>V1APRF631/B</b>	

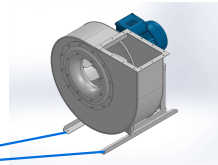
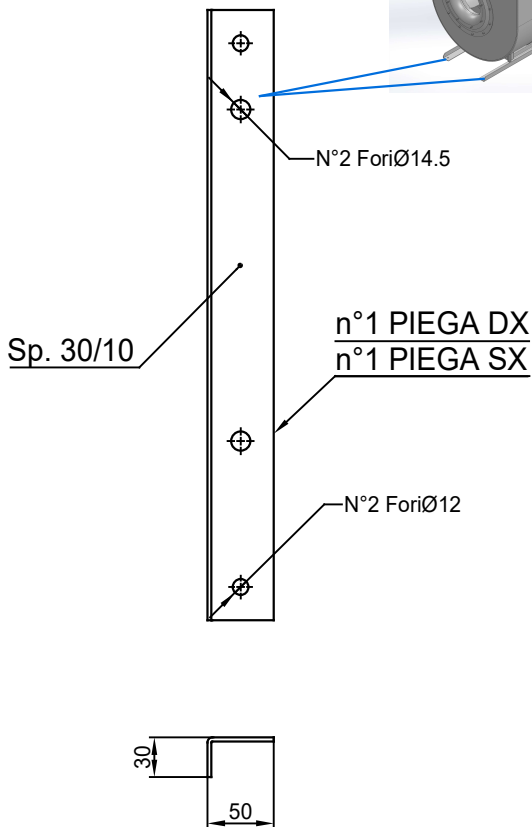
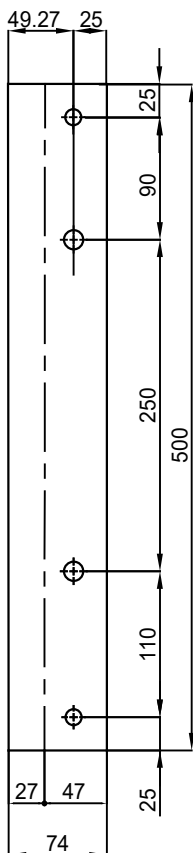

COMM.  
N°

00	02/02/2016	PRIMA EMISSIONE		RK	RK	
01	16/09/2020	Extension pedestal		MvS	MvS	
REV	DATA - DATE	DESCRIZIONE - DESCRIPTION		DISEGNATO PREPARED	CONTROLLATO CHECKED	
DESCRIZIONE - DESCRIPTION			MATERIALE - MATERIAL	NR. FILE	PESO - WEIGHT	
DESCRIZIONE - DESCRIPTION			Fe 360		Kg	
Staffe per Puffer L=500 IEC 132 / AP series			SCALA	1.4	DISEGNATO - PREPARED	FORMATO
			DATA	02/02/2016	RK	A4
			SOSTITUISCE IL - REPLACES THE N°			
			SOSTITUITO DAL - REPLACES BY N°			
N. DISEGNO - N. DRAWING				REV.		
STF-AP13201ST				01		

