

APF 901C



Centrifugal fan model APF Es.4

Single inlet fan, direct driven with an IEC-standard motor in form B3 which is mounted on a motorbase. The overhang impeller is mounted on the motor shaft and has forward curved blades. The blades are welded between the back plate disc and the aerodynamically formed front plate. The fan is suitable for pneumatic transport, in cement plants, in the air supply of cabinets, in foundries and in oil burners, in mills, in pasta factories, in the chemical, iron and steel industry, in the metallurgical industry where small flows with medium and high pressure are required.

General data:

Drive	direct
Motor position	horizontal
Material casing/base	Steel
Material impeller/hub	Steel
Motorcoating/protection	RAL 7037
Operating temperature (max.)	15 (80) °C
Medium density (altitude 0 m)	1,226 kg/m ³
Impeller speed	2960 rpm
Weight	798 kg
Sound pressure level ±3	91 dB(A)

(at 1,5 m near the fan with inlet and outlet ducted, in free field)

Electric motor:

	225M	IEC
Power	45	kW
Motor speed	2.960	rpm
Electric supply	3x400V50Hz	V/Hz
Full load current	77,5	A
Enclosure	55	IP
Shape	B3T	
Efficiency class	IE3	

Curve APF 901C @ 2960rpm @ 15°C @ 0m

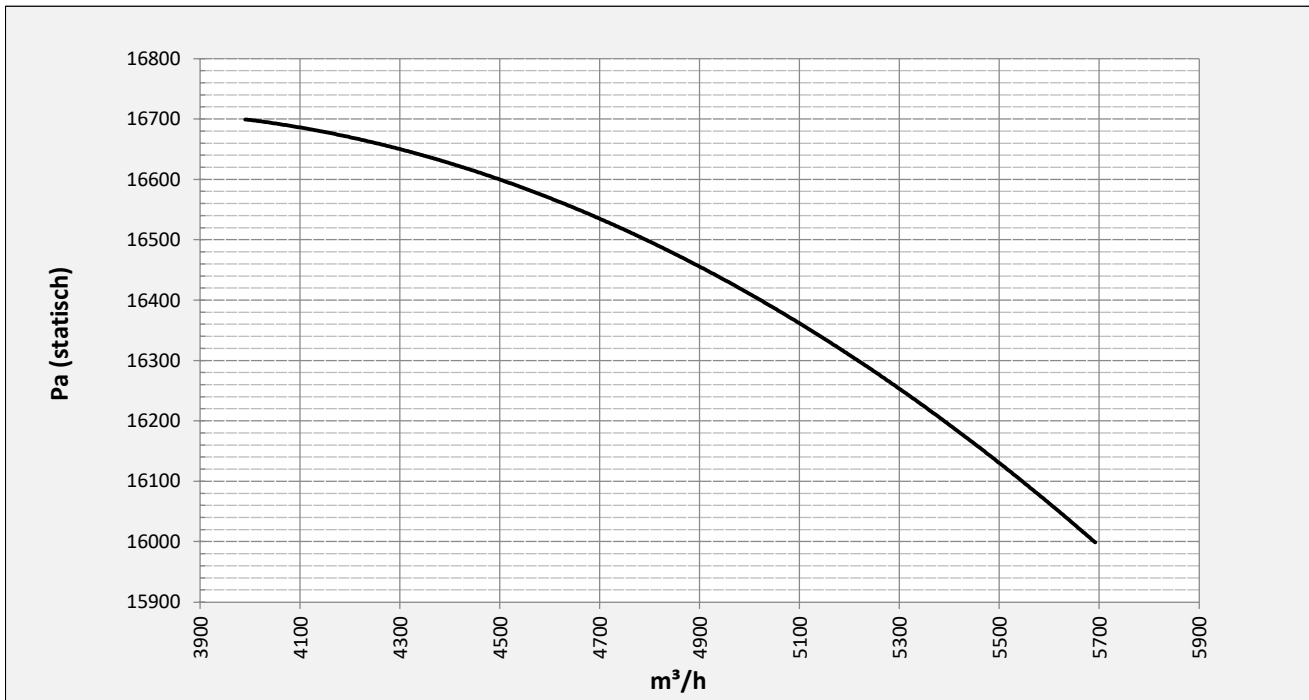

Possible discharge positions:



* (Pos 180 and 225 extra price)

Possible accessories

Mounting profiles for load distribution	--
Counterflange inlet/outlet	zz Ø280 / pz 224x160
Flexible connection inlet/outlet max. 80°C	zz Ø315 / pz Ø315
Anti-vibration mountings	4x 100x55/B/70° ShA
Inspection door	
Drain connection	
Shaft seal without asbestos	
Cooling wheel (medium max. 150°C)	(incl. coating RAL9006)
Flexible connection inlet/outlet max. 150°C	zz Ø315 / pz Ø315
ATEX version	Zone 1 / 2 / 21 / 22
ATEX motor	Ex nA / Exe / Ex de
Coating suitable for outdoor application	RAL 5010 / RAL
Stainless steel version	304 / 316 / ...
Acoustic enclosure	

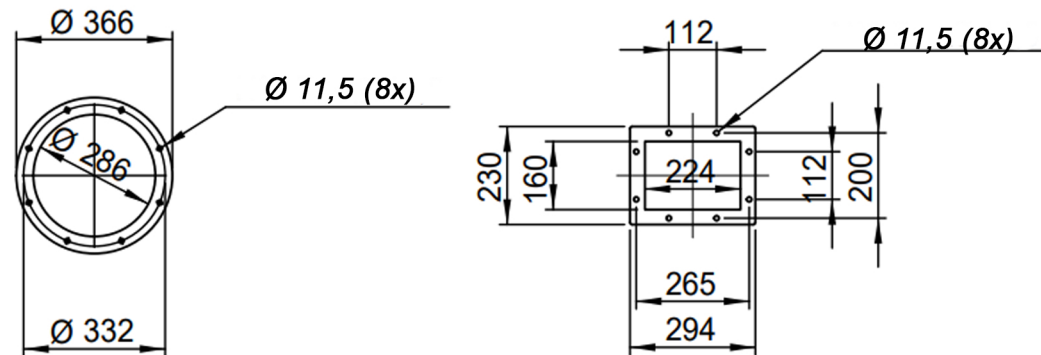
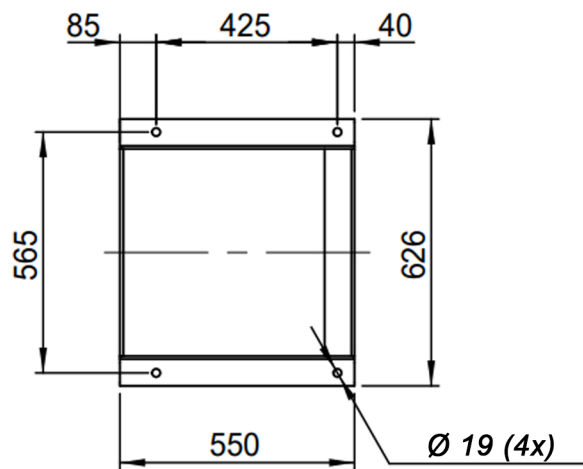
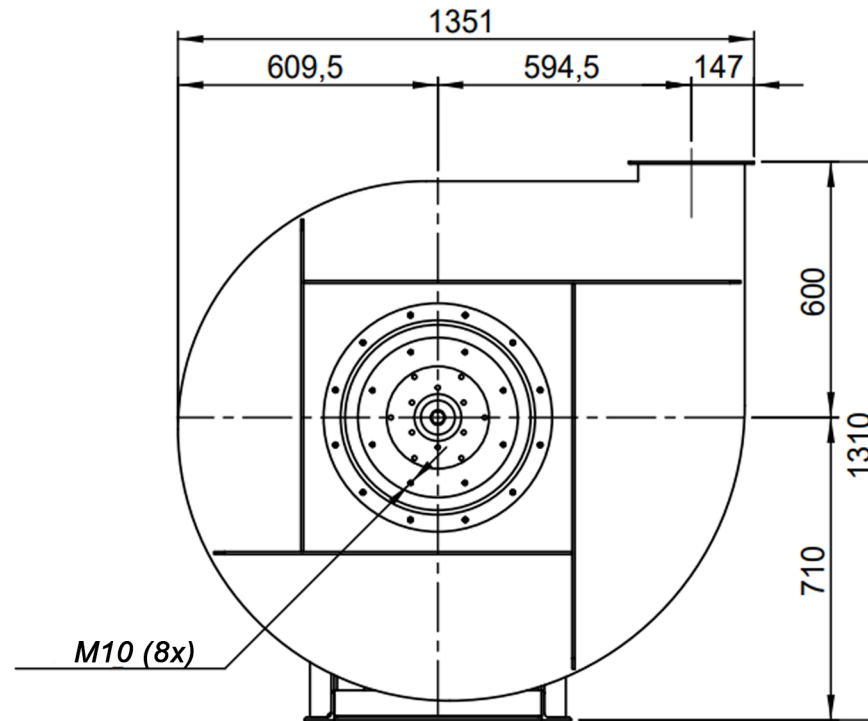
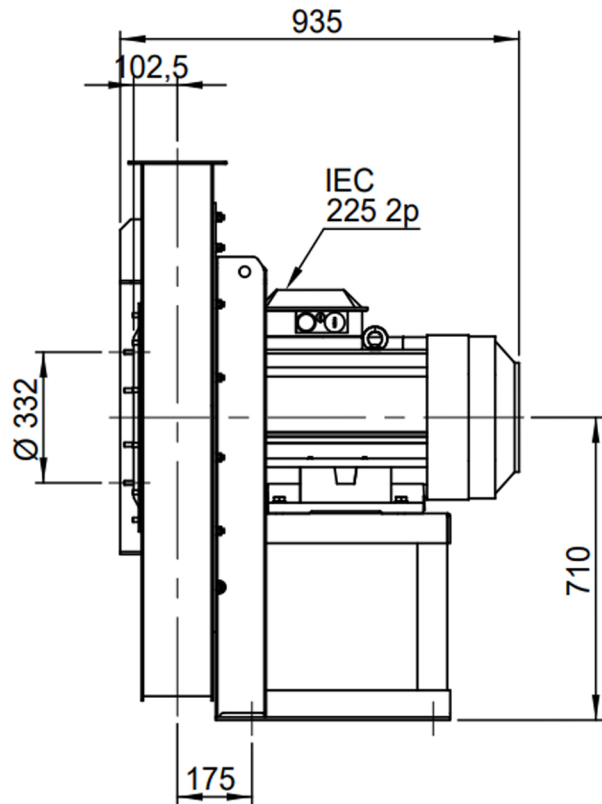

DESCRIPTION-BESCHRIJVING APF901/C - RD0	SCHAAL 1:18	GEMAAKT - PREPARED Overmeer E.	FORMAAT A4
	DATUM 10/11/2023		REV. 00
N.TEKENING - N.DRAWING		REV.	
		V1APF901/C	